

A 3D Geometry Modeler for the SUMMiT V MEMS Designer

Craig Reed Jorgensen* and Victor R. Yarbey**

Sandia National Laboratories, PO Box 5800, MS 1080
Albuquerque, NM 87185, *crjorge@sandia.gov, **vryarbe@sandia.gov

ABSTRACT

This paper will describe the SUMMiT V 3D Modeler; a 3D geometric modeler based on Sandia National Laboratories new five-level process for manufacturing microelectromechanical systems (MEMS). The modeler simulates the SUMMiT V process, a baseline surface-micromachining process using low-stress polysilicon as its mechanical material. The resulting 3D model is an accurate representation of the MEMS device including artifacts like stringers and trapped oxide. The model can be used for visualization, analysis, dynamic modeling, rapid prototyping, etc. Several examples of the modeler are shown.

Keywords: 3D Modeling, MEMS, solid modeling, SUMMiT V.

1 INTRODUCTION

Sandia National Laboratories has recently unveiled its new five-level SUMMiT (Sandia Ultra-Planar Multilevel MEMS Technology) process [1]. The increased number of mechanical layers allows the creation of more complex MEMS devices, but also increases the demands placed on the designers of these devices. With this in mind, Sandia has developed several tools that support SUMMiT V designers: the 2D Process Visualizer, the 3D Modeler and the Design Rule Checking System. This paper will discuss the 3D Modeler.

The SUMMiT 3D Modeler is a solid geometry modeler based on the ACIS kernel [2]. It builds a 3D geometric model of a MEMS device by simulating the manufacturing process using a mask set and a process definition file. The resulting solid model is in a standard commercial file format that can be used for visualization, analysis, dynamic modeling, rapid prototyping, etc.

The process definition file contains the simplified processing steps for the SUMMiT V process. Since the SUMMiT V process is not hardwired into the code, it is straightforward to explore how changes in the process would affect resulting MEMS device.

2 3D MODELER DESCRIPTION

The SUMMiT 3D Modeler works by interpreting each step in the process definition file. These steps add new layers of material to the model and etch the existing model

by cutting away material depending on the masks. The resulting solid model is an accurate representation of the MEMS device and includes process artifacts like stringers and trapped oxide (see Figures 9 - 12).

There are currently 5 types of simulated process steps for the modeler; Conformal Deposition, Planar Deposition, Dry Etch, Wet Etch and Release Etch.

Each of the existing processing steps is described below and has a simple example of how the simulation step is used. The examples show different points in the development of a rotating gear hub.

2.1 Conformal Deposition

The Conformal Deposition step simulates chemical vapor deposition (CVD) by adding a conformal layer of material to the model. This conformal layer can be uniform or non-uniform. A uniform deposition creates a new layer of constant thickness material across all of the model surfaces. A non-uniform deposition means that the thickness of the new model coating varies depending on the orientation of the coated face. Faces with normals that are pointing up receive a thicker deposit of material than faces that have their normals pointing to the side.

Figure 1 shows a non-uniform conformal deposition. The top layer of material has covered the model and has a thickness of 100%, 75%, and 50% with regards to top, side and bottom faces, respectively. Figure 2 shows a close-up of the non-uniform deposition

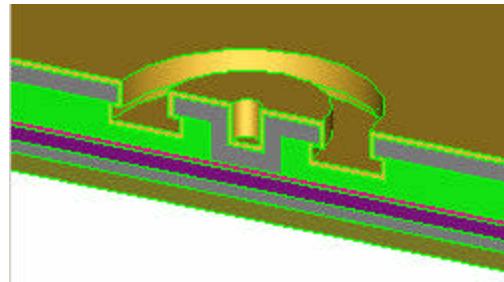

Figure 1: A non-uniform conformal deposition of sacrificial oxide for a gear hub.

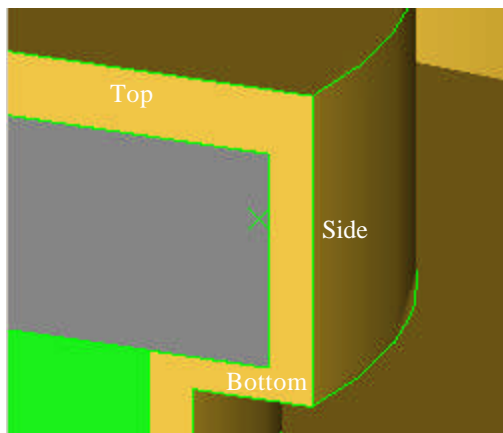

Figure 2: A close-up of the non-uniform conformal deposition.

2.2 Planar Deposition

The Planar Deposition step imitates a deposition and chemical-mechanical polish (CMP). It adds a new layer of material to the existing model that is planarized flat on the top. This SUMMiT step reduces the effect of underlying topology on upper layers of material. The top layer in figure 3 shows a planar deposition in a model.

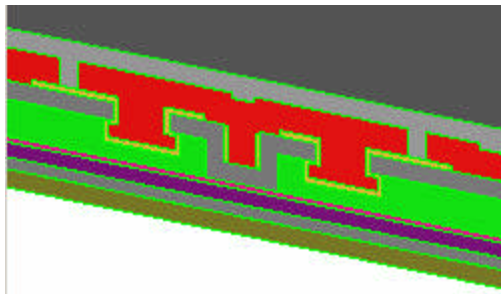

Figure 3: A planar deposition of sacrificial oxide for a gear hub

2.3 Dry Etch

The Dry Etch step uses the input masks to “etch”, or remove, material from the model. The process definition file defines which type of material in the model is modified and the depth of the etch. The cut can affect multiple layers of material, one layer of material, or can be blocked if the proper material is not exposed to the etch. Currently, etches are assumed to be perfectly vertical resulting in straight sidewalls from the cut. This can cause an overestimation in the amount of trapped oxide that exists in the final model. An example of a dry etch is shown in

Figure 4. The top dark gray layer has just had a circular etch applied to it.

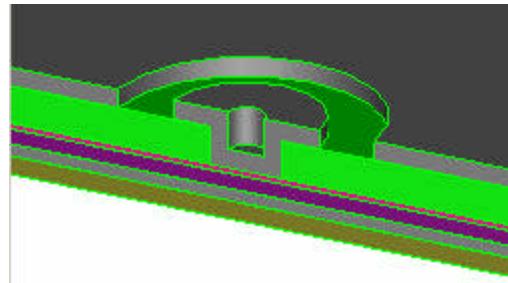

Figure 4: A dry etch to expose the sacrificial oxide for the next step, a wet etch, for a gear hub.

2.4 Wet Etch

The Wet Etch step simulates an isotropic etch which is a timed acid etch that selectively attacks exposed sacrificial oxide. This etch can remove model material that is underneath shielding material (see figure 4). It is the step which allows the SUMMiT V process to create underetches that can be used for gear hubs.

Figure 5 shows an example of a wet etch. The wet etch has attacked the sacrificial oxide (the light gray) and removed material from underneath the polysilicon (top dark gray material)

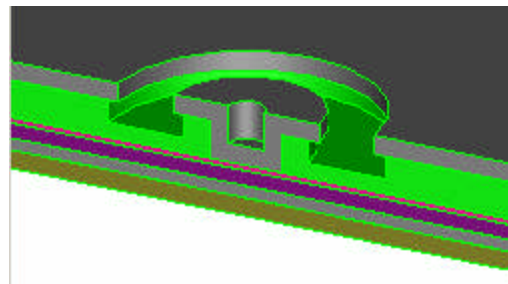

Figure 5: A wet etch to create the hub of a gear.

2.5 Release Etch

The Release Etch step is used to free mechanical parts by removing sacrificial oxide. This etch can be considered a long Wet Etch. For the 3D Modeler the Release Etch is assumed to be complete, meaning that all non-trapped oxide is removed.

Figure 6 shows a device before the release etch and Figure 7 shows the same device after release.

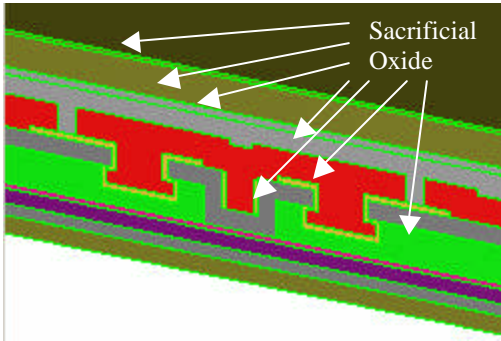

Figure 6: Immediately before the release etch of a gear

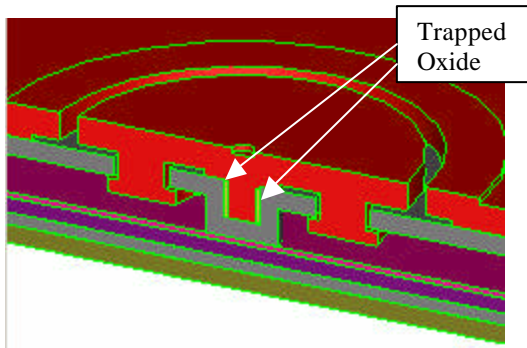

Figure 7: After the release etch of a gear.

3 USER INTERFACE

Sandia uses AutoCAD [3] to design its MEM devices for the SUMMIT V process. The 3D Modeler has been incorporated into the AutoCAD environment allowing the user to press a button and select the area of design that they want modeled. When the modeler finishes the user can load the results into AutoCAD for viewing or use the model results with another program.

4 MODELING TIMES

As with most modeling there is a trade-off between accuracy and speed. Table 1 indicates some of the processing time on a 450 MHz Pentium III NT workstation with 1 Gigabyte of RAM. The number of vertices in the design is a simple indication of the complexity of the part.

<u>Part Description</u>	<u>Vertices</u>	<u>Time (seconds)</u>
Simple Gear Clip	42	19
17-tooth Gear	1156	297
Transmission Gear	5285	6813

Table 1: Modeling Speed

5 FUTURE WORK

Work is continuing on the SUMMIT 3D modeler. There is an effort to increase both the speed and accuracy of the modeling, including edge blending and angled sidewalls. This work could split into different tracks to accommodate those that want quick and dirty results and those that are willing to wait for high-resolution modeling.

6 ACKNOWLEDGEMENT

This work was supported by the United States Department of Energy under Contract DE-AC04-94AL85000. Sandia is a multiprogram laboratory operated by Sandia Corporation. A Lockheed Martin Company for the United States Department of Energy.

REFERENCES

- [1] M. S. Rodgers, J. J. Sniegowski, "Designing Microelectromechanical Systems-on-a-Chip in a 5-Level Surface Micromachine Technology", 2nd International Conference on Engineering Design and Automation, 1998.
- [2] ACIS by Spatial Corporation, <http://www.spatial.com>
- [3] AutoCAD by Autodesk, <http://www.autocad.com>



Figure 8: A scanning electron micrograph (SEM) of a linkage gear hub produced by focussed ion beam milling.

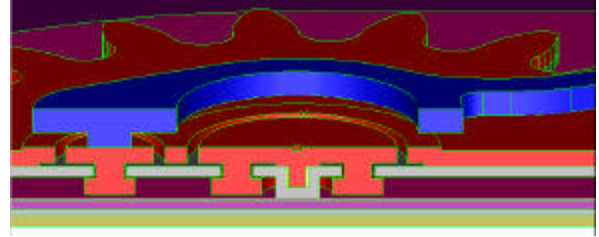

Figure 9: A cut 3D model of a gear hub



Figure 10: A SEM of a Transmission Gear

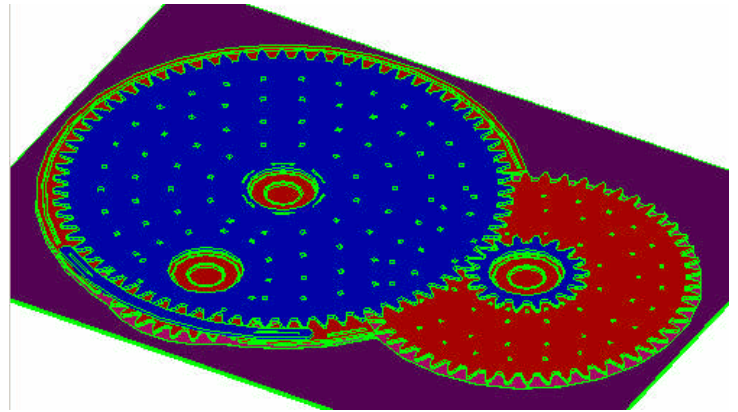

Figure 11: A 3D model of a Transmission Gear

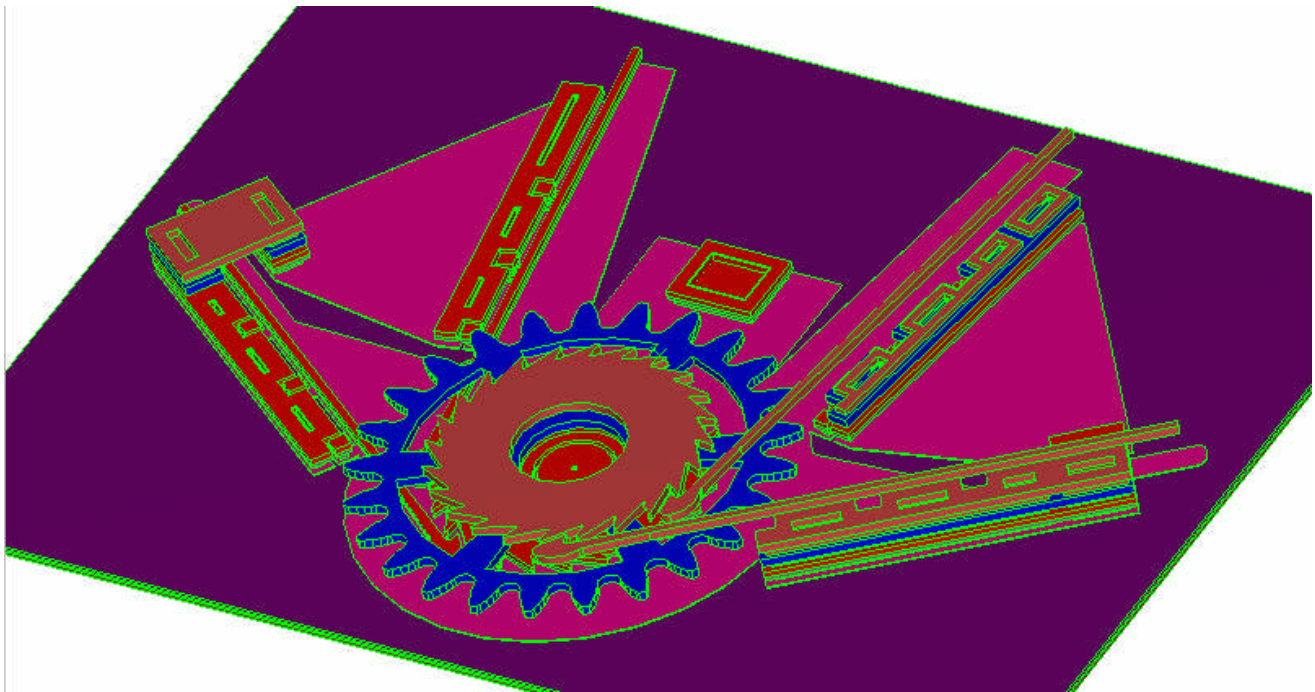

Figure 12: A 3D model of a ratchet gear