



2Q2020 Highlights

NFPA 855 2020 has been published as a standard and the NFPA 855 Committee has begun deliberations for revisions to be included in NFPA 855 2023.

The second draft report on NFPA 791 has closed including the filing of a NITMAM.

The second draft report on NFPA 1 has closed including the filing of a NITMAM.

The 2021 ICC Group B Codes updates are complete and should be published in Summer 2020.

The 2nd edition of UL 9540 was published February 27, 2020.

The 4th Edition of ANSI/CAN/UL 9540A was published on November 12, 2019.

CODES AND STANDARDS UPDATE SPRING 2020

The goal of the DOE OE Energy Storage System Safety Roadmap¹ is to *foster confidence in the safety and reliability of energy storage systems*. There are three interrelated objectives to support the realization of that goal: [1] research, [2] codes and standards (C/S) and [3] communication/coordination. The objective focused on C/S is “*To apply research and development to support efforts focused on ensuring that codes and standards are available to enable the safe implementation of energy storage systems in a comprehensive, technology agnostic, and science-based manner.*”

The following activities support that objective and realization of the goal:

- a. Review and assess C/S which affect the design, installation, and operation of energy storage systems (ESS).
- b. Identify gaps in knowledge that require research and analysis to provide data for technical committee inputs.
- c. Identify areas in C/S that are potentially in need of revision or enhancement and can benefit from activities conducted under research and development.
- d. Develop input for new or revisions to existing C/S through individual stakeholders, facilitated task forces, or through laboratory staff supporting these efforts.

The purpose of this Codes and Standards Update is to support these objectives by providing information on efforts being conducted by U.S. standards developing organizations (SDOs) and other entities that include focus on ESS safety.

The information is organized by SDO relative to the scope of each document in relation to how it fits into the ESS paradigm. The categories are color coded as codes and standards that apply as follows: **[1] Built Environment;** **[2] Complete ESS;** **[3] ESS Installation;** **[4] ESS Components;** and **[5] Reference Items**

Changes in current activity from the prior edition are shown in italics. Time-sensitive items (e.g., those having an upcoming schedule/due date) are shown as **highlighted, bold and underlined**.

To subscribe to the ES Safety Collaborative and receive ongoing ESS safety- related communications visit https://public.govdelivery.com/accounts/USDOESNLEC/subscriber/new?topic_id=USDOESNLEC_195

¹ DOE OE Energy Storage Systems Safety Roadmap, PNNL-SA-126115 | SAND2017-5140 R https://www.sandia.gov/ess-ssl/publications/EnergyStorage_safetyroadmap_2017.pdf

	American Society of Heating, Refrigeration and Air Conditioning Engineers – www.ashrae.org [ESS Installation]
Document Name:	ASHRAE 18: Guide for the Ventilation and Thermal Management of Batteries for Stationary Applications
ESS Relevance:	Guide to understanding the ventilation and thermal management characteristics of vented lead-acid (VLA) and valve-regulated (VRLA) lead-acid and nickel-cadmium (Ni-Cd) cells used in stationary battery applications, and how to properly manage this in installations of those cells.
Date of Current Edition:	2018
Date of Next Edition:	2021
Current Activity:	Working in collaboration with IEEE 1635 (see below). Engineering applying within ASHRA to set up a GPC 21 Committee to work with IEEE ESSB in formulating revisions needed, including addressing lithium batteries, in the next edition.

	American Society of Mechanical Engineers (ASME) – www.asme.org [Complete ESS]
Document Name:	TES-1: Safety Standard for Thermal Energy Storage Systems
ESS Relevance:	Provides safety-related criteria for molten salt thermal energy storage systems.
Date of Current Edition:	New Standard
Date of Next Edition:	June 2020 (anticipated)
Current Activity:	The TES-1 draft has received ANSI approval and is now in the publication process. The Committee has begun considering revisions for the next edition.

	American Society of Mechanical Engineers (ASME) – www.asme.org [Complete ESS]
Document Name:	TES-2: Safety Standard for Thermal Energy Storage Systems, Requirements for Phase Change, Solid and Other Thermal Energy Storage Systems
ESS Relevance:	The TES-2 standard will provide guidance on the design, construction, testing, maintenance, and operation of thermal energy storage systems, including but not limited to phase change materials and solid state energy storage media. This standard will be suitable for use by manufacturers, owners, employers, users, and others concerned with, or responsible for its application by prescribing safety requirements.
Date of Current Edition:	New Standard
Date of Next Edition:	TBD
Current Activity:	A PINS has been filed with ANSI to develop a new standard. The TES Standards Committee is currently seeking participants with in-depth knowledge of phase change thermal energy storage systems who are interested in joining the committee. A kick-off meeting is expected to take place in May 2020. For more information or to join the Committee, contact Nicole Gomez at gomezn@asme.org .

	American Society of Mechanical Engineers (ASME) – www.asme.org [Reference Item]
Committee Name:	The Energy and Environmental Advisory Board has authorized the creation of an ASME Energy Storage Committee as well as an ASME Performance Test Committee.
ESS relevance:	These two committees will look into both how the ESC can fill gaps with necessary standards while the PTC will provide information on Mechanical and Thermal Energy ESS (see TES 1 & TES 2). Goal is to provide ESS guidance to its members as well as the industry at large.
Date of Next Meeting:	First organizational meeting held on April 13, 2020. A follow-on meeting is planned for the week of May 25, 2020.
Current Activity:	Currently the Committee is by invitation only, but IEEE ESSB and other SDO's/groups have been invited to participate. More information to follow as this new group advances.

	CSA GROUP (CSA) – www.csagroup.org [ESS Installation]
Document Name:	C22.1 Canadian Electrical Code, Part I (25th edition), Safety Standard for Electrical Installations
ESS Relevance:	The object of this Code is to establish safety standards for the installation and maintenance of electrical equipment. In its preparation, consideration has been given to the prevention of fire and shock hazards, as well as proper maintenance and operation. Section 64 provides requirements for the installation of renewable energy, energy production, and energy storage systems.
Date of Current Edition:	2018
Date of Next Edition:	2021
Current Activity:	A proposal to include energy storage system installation and consolidation with the battery installation requirements prepared and submitted to the committee. Align with this proposal Section 64 Sub-rule 800s and Sub-rule 900s are dealing with batteries and energy storage system installation requirements. For more information about the latest status please contact Mohsen Sephr at Mohsen.sephr@csagroup.org .

	CSA GROUP (CSA) – www.csagroup.org [ESS Components]
Document Name:	CSA C22.2 No. 107.1: Power Conversion Equipment
ESS Relevance:	Applies to alternating current (AC) and direct current (DC) type power conversion equipment which can be associated with an energy storage system.
Date of Current Edition:	2016
Date of Next Edition:	2021
Current Activity:	This standard is under continuous maintenance and updated as warranted. See https://webstroe.ansi.org/Standards/CSA/CSAC221072016 for more information on the standard.

	DNV GL – www.dnvgl.com/rules-standards/ [Complete ESS]
Document Name:	DNVGL-RP-0043: Safety, Operation, and Performance of Grid-Connected Energy Storage Systems (GRIDSTOR)
ESS Relevance:	The objective of GRIDSTOR is to provide a comprehensive set of recommendations for grid-connected energy storage systems. It aims to be valid in all major markets and geographic regions, for all ESS applications. As an overarching guide its aim is to serve at all levels from component to complete system while covering the entire life cycle. End users, operators, and other stakeholders can find specific guidance in the document and references to other relevant standards, codes, and guidelines.
Date of Current Edition:	October 2017
Date of Next Edition:	TBD
Current Activity:	Supporting the second edition of GRIDSTOR released in September 2017. See https://www.dnvgl.com/services/gridstor-recommended-practice-for-grid-connected-energy-storage-52177 for more information.

	FM Global – www.fmglobal.com [Complete ESS]
Document Name:	FM Global Property Loss Prevention Data Sheet # 5-33: Electrical Energy Storage Systems
ESS Relevance:	The data sheet describes loss prevention recommendations for the design, operation, protection, inspection, maintenance, and testing of electrical energy storage systems, which can include batteries, battery chargers, battery management systems, thermal management and associated enclosures and auxiliary systems. The focus of this data sheet is primarily on lithium-ion battery technology.
Date of Current Edition:	January 2017
Date of Next Edition:	TBD
Current Activity:	Work to update the data sheet via an interim revision will begin in 2019. Typically, data sheets are developed internally at FM Global with support from FM Global field operations. See https://www.fmglobal.com/research-and-resources/fm-global-data-sheets for more information.

	FM Global – www.fmglobal.com [Reference Item]
Document Name:	Project ID RW000029: Development of Sprinkler Protection Guidance for Lithium-Ion Based Energy Storage Systems
ESS Relevance:	Fire protection recommendations for Lithium-ion battery based energy storage systems located in commercial occupancies have been developed through fire testing. This report describes Phase 2 of a multi-phase project conducted in conjunction with the Property Insurance Research Group (PIRG) and in partnership with the Fire Protection Research Foundation (FPRF).
Date of Current Edition:	June 2019
Date of Next Edition:	TBD
Current Activity:	Need to investigate if any updates are planned.

	International Code Council (ICC) – www.iccsafe.org [Built Environment]
Document Name:	International Building Code (IBC)
ESS Relevance:	The IBC is an overarching code that provides minimum requirements to safeguard the public health, safety and general welfare of the occupants of new and existing buildings and structures. The IBC is fully compatible with the entire family of ICC codes including the International Fire Code (IFC), International Residential Code for One and Two-Family Dwellings, the International Green Construction Code (IgCC) among other ICC Codes. 35 Chapters make up the body of the IBC. Chapter 9 deals with Fire Protection Systems while Chapter 10 deals with Means of Egress. Chapter 13 deals with Energy Efficiency while Chapter 27 covers electrical issues referencing the various code sections requiring emergency and standby power, such as high-rise buildings and containing hazardous materials. Appendix D provides a useful tool to limit conflagration hazards in areas of a city with intense and concentrated development.
Date of Current Edition:	2018
Date of Next Edition:	2021
Current Activity:	Note: Beginning with the development of the 2021 edition of the I-Codes, there will be two groups of code development committees which will meet in separate years. The IFC and the General, Egress and Fire Safety Development Committees are part of the Group A Codes. The IRC is classified as a Group B Code. Deadline for recommended revisions the 2021 Codes will be early January 2021.

	International Code Council (ICC) – www.iccsafe.org [Built Environment]
Document Name:	International Fire Code (IFC)
ESS Relevance:	Chapter 12 of the IFC covers energy systems and Section 1206 in that chapter covers electrical energy storage systems. The ICC code development process (CDP) associated with the 2021 IFC has been completed and the new edition should be published by October 2020. During the process the provisions of the 2018 IFC related to ESS were enhanced to follow the requirements of NFPA 855.
Date of Current Edition:	2018
Date of Next Edition:	2021 (Expected release in the fall of 2020)
Current Activity:	A high-level summary of the provisions of the 2015, 2018 and 2021 editions of the IFC is under development. Information on the adoption of the I-Codes is available at https://www.iccsafe.org/advocacy/ . Efforts to revise the 2021 IFC are expected to start sometime in 2020 and will include efforts of an ES Task Force under the ICC Fire Code Action Committee. Note that anyone can submit a proposed change to the 2021 IFC (or other I-Codes). See https://www.iccsafe.org/products-and-services/i-codes/code-development/ for more information.

	International Code Council (ICC) – www.iccsafe.org [Built Environment]
Document Name:	International Residential Code (IRC)
ESS Relevance:	Chapter 2 -Definitions, Chapter 3 -Building Planning: Section 327 Energy Storage Systems referred to as Stationary Storage Battery Systems in the 2015 edition; excludes Chapter 11 Energy Efficiency where all proposals regarding energy (IRC and IECC) are lumped together (see activity under IECC below).
Date of Current Edition:	2018
Date of Next Edition:	2021
Current Activity:	<p>The 2019 Group B Public Comment Hearings (PCH) which ended October 30, 2019 are now available. Click here for the full results. The Online Governmental Consensus Vote (OGCV) opened November 18, 2019 and closed December 6, 2019. Below is a short summary of the PCH results. A more detailed list is provided in the Special Briefing Update Paper, December 2019.</p> <p>Two proposals were approved that were editorial: [1] removing “stationary” storage and [2] “battery” and replacing with “energy” storage system; Other proposals included adding new definitions for renewable energy resources and on-site renewable energy, plus a new section on commissioning. One proposal to include grid interactive electrical energy storage was disapproved. Two proposals to revamp R327 were initially disapproved (RB153 and RB154). During the PCH, RB154 was approved as modified with requirements for minor protections to rooms containing ESS. New Section R328 on fuel cell power systems including a new definition was approved as modified from the original proposal submitted. Provisions for adding an ESS room for separation and material installation was disapproved.</p>

	International Code Council (ICC) – www.iccsafe.org [Built Environment]
Document Name:	International Building Code-General (IBC-G) Chapter, International Residential Code Plumbing (IRC-P) and Mechanical (IRC-M) Chapters
ESS Relevance:	IBC G– General, IBC-E Egress, IBC-FS Fire Safety provisions, IFC Chapter 10 maintained by IBC-E, IMC, IPC, IRC-M, IRC-P
Date of Current Edition:	2018
Date of Next Edition:	2021
Current Activity:	IBC-G adds “ESS in dedicated use buildings” to the list of building types that are considered moderate-hazard factory industrial, Group F-1 buildings; deletes the stationary storage battery system room/area requirements from the table providing required separation and/or protection requirements (the room is anticipated to be covered under revised Section 1206 of the IFC); adds a new Section 3114 covering intermodal shipping containers that are repurposed for use as buildings or structures or as a part of a building or structure but includes an exemption for stationary storage battery arrays located in such containers complying with Chapter 12 of the IFC (modifications do not impact the exception). IBC-FS adds water as a component of certain battery types in the definition (lead acid and Ni-Cd); requires that electrical equipment, wiring and systems be installed, used, and maintained in accordance with NFPA 70 and provisions in Section 604.2 through 604.11 of the IFC; and a comprehensive revision of the provisions in IFC that cover ESSs (see Special Briefing Paper, November 2018 for more details on code changes).

	Institute of Electrical and Electronics Engineers – www.ieee.org [Built Environment]
Document Name:	IEEE 1547.9: Guide for Interconnection of Energy Storage Distributed Energy Resources (DER) with Power Systems
ESS Relevance:	This Guide provides information on and examples of how to apply IEEE Standard 1547, “IEEE Standard for Interconnection and Interoperability of Distributed Energy Resources with Associated Electric Power Systems Interfaces,” to the interconnection of Energy Storage Distributed Energy Resources (DER ES) including DER ES connected to Electric Power Systems (EPS) capable of bidirectional real power exchange with the EPS
Date of Current Edition:	New Standard
Date of Next Edition:	2021 (anticipated)
Current Activity:	An active IEEE Working Group made up of members from both the IEEE ESSB and IEEE SCC 21 are jointly in the process of developing the Guide. The next meeting is scheduled for June 8-10, as a virtual meeting. Interested parties wishing to join this WG are encouraged to contact Charlie Vartanian at Charlie.vartanian@pnnl.com or Jim McDowall at jim.mcdowall@saftamerica.com .

 <p>IEEE Advancing Technology for Humanity</p>	Institute of Electrical and Electronics Engineers – www.ieee.org [ESS Installation]
Document Name:	IEEE 1578: Recommended Practice for Stationary Battery Electrolyte Spill Containment and Management
ESS Relevance:	Provides descriptions of products, methods, and procedures relating to stationary batteries, battery electrolyte spill mechanisms, electrolyte containment and control methodologies, and firefighting considerations.
Date of Current Edition:	2018
Date of Next Edition:	TBD (IEEE SA allows a 10-year period before the standard must be renewed or revised)
Current Activity:	None. The standard was approved October 23, 2018 and is available at https://standards.ieee.org/standard/1578-2018.html

 <p>IEEE Advancing Technology for Humanity</p>	Institute of Electrical and Electronics Engineers – www.ieee.org [ESS Components]
Document Name:	IEEE 1679.1: Guide for the Characterization and Evaluation of Lithium-Based Batteries in Stationary Applications
ESS Relevance:	The first in a series of Guides and Best Practices under the IEEE 1679 base standard that will cover various merging Battery Energy Storage technologies used in Battery Energy Storage Systems (BESS) including safety issues. Each guide in this series will follow a similar pattern to aid the user in a synergistic manner. The guide points to existing safety standards (e.g., UL 1642) and existing regulatory requirements. This guide focuses on lithium-ion batteries.
Date of Current Edition:	2017
Date of Next Edition:	TBD (IEEE SA allows a 10-year period before the standard must be renewed or revised)
Current Activity:	An active working group is engaged in considering updates to the standard. See https://standards.ieee.org/standard/1679_1-2017.html for more information.

 <p>IEEE Advancing Technology for Humanity</p>	Institute of Electrical and Electronics Engineers – www.ieee.org [ESS Components]
Document Name:	IEEE 1679.2: Guide for the Characterization and Evaluation of Sodium-Beta Batteries in Stationary Applications
ESS Relevance:	The second in a series of guides and best practices under the IEEE 1679 base standard that will cover various merging battery energy storage technologies used in Battery Energy Storage Systems (BESS) including safety issues. Each guide in this series follows a similar pattern to aid the user in a synergistic manner. The guide points to existing safety standards and existing regulatory requirements. This guide focuses on sodium-beta batteries.
Date of Current Edition:	2018
Date of Next Edition:	TBD (IEEE SA allows a 10-year period before the standard must be renewed or revised)
Current Activity:	None. See https://standards.ieee.org/standard/1679_2-2018.html for more information.

 IEEE <i>Advancing Technology for Humanity</i>	Institute of Electrical and Electronics Engineers – www.ieee.org [ESS Components]
Document Name:	IEEE P1679.3: Guide for the Characterization and Evaluation of Flow Batteries in Stationary Applications
ESS Relevance:	The third in a series of guides and best practices under the IEEE 1679 base standard that will cover various merging battery energy storage technologies used in Battery Energy Storage Systems (BESS) including safety issues. Each guide in this series follows a similar pattern to aid the user in a synergistic manner. The guide points to existing safety standards and existing regulatory requirements. This guide focuses on flow battery technologies.
Date of Current Edition:	New Standard
Date of Next Edition:	2021
Current Activity:	The working group met at the IEEE ESSB 2020 Winter General Meeting in Orlando FL, February 2020 (https://cmte.ieee.org/pes-essb/). If participation in this working group interests you, contact: Vilayanur (“Vish”) Viswanathan, vilayanur.viswanathan@pnnl.gov .

 IEEE <i>Advancing Technology for Humanity</i>	Institute of Electrical and Electronics Engineers – www.ieee.org [Reference Item]
Committee Name:	IEEE PES Energy Storage and Stationary Battery Committee (ESSB)
ESS Relevance:	This is a growing subcommittee within the IEEE Power and Energy Society (PES) that manages many of the safety and reliability standards related to energy storage and battery technologies, both traditional and emerging BESS. http://sites.ieee.org/pes-essb/ .
Date of Next General Meeting:	February 2021: Birmingham AL (exact dates and location to be confirmed)
Current Activity:	<p>An ESSB Safety Codes and Standards Working Group has mobilized their efforts to play a more active role within IEEE to effectively interact with various safety codes organizations and ensure that safety codes and standards are understood in the development of IEEE standards related to energy storage systems, batteries and DC power systems. A liaison has been formed with the DOE National Laboratories engaged in ESS efforts to track and productively influence codes and standards development by other organizations that are related to energy storage systems.</p> <p>In March 2019, a collaborative Energy Storage Task Force (ESTF) effort between IEEE SA SCC 21 (home of the 1547 series of grid interconnectivity standards) and the IEEE ESSB was renamed the Energy Storage Collaboration Team (ESCT). The scope of the ESCT is to coordinate standards development for energy storage systems among IEEE Societies and technical committees as well as other standards development groups.</p> <p>An example of this collaborative effort is the joint sponsorship with IEEE SCC 21 of IEEE P1547.9, a Guide for ES Interconnection with the grid, which had its kick-off working group (WG) meeting in February 2019 at NERC headquarters in Atlanta. This is a very active working group and invites interested parties to become involved. Contact Michael Ropp at michael.ropp@sandia.gov or jim.mcdowall@saftamerica.com.</p> <p>The Codes Working Group of the ESSB Committee is working with UL to refine the UL9540, UL9540A, and UL1973 standards to permit more appropriate testing for traditional aqueous batteries, e.g. lead-acid and NiCd batteries. This would allow UL listing that meets NFPA 855 requirements.</p> <p>Other active IEEE ESS standards working groups developing new guides or best practices are P1679.3 for Flow Batteries, and P2686 for Battery Management Systems (BMS).</p>

 <p>IEEE Advancing Technology for Humanity</p>	Institute of Electrical and Electronics Engineers – www.ieee.org [Built Environment]
Document Name:	IEEE C2: National Electric Safety Code (NESC)
ESS Relevance:	Standard that covers electrical safety for utility systems and equipment.
Date of Current Edition:	2017
Date of Next Edition:	2022
Current Activity:	<p>NESC Sub-Committees held meetings in 2019 to consider change proposals submitted by the member representatives and prepared recommendations on each of them. During those meetings the NESC battery section was reorganized into three sections (general, protection and control, and grid storage). The grid storage section is new and provisions for fire protection and spill control were added to that section. NESC submitted a NITMAM to NFPA to exclude utilities who follow NESC (IEEE C2-17) from the new NFPA 855 standard. This NTMAM was approved by the General Membership but ultimately rejected by the NFPA Technical Council. Subsequently, NESC submitted a Tentative Interim Amendment (TIA) to the American National Standards Institute (ANSI) to revise this standard to incorporate emerging battery technologies to be used in utility environments. The link to ANSI Standards Action where the TIA is the first item listed is: https://share.ansi.org/Shared%20Documents/Standards%20Action/2019-PDFs/SAV5049.pdf</p> <p>See http://standards.ieee.org/about/nesc/ and https://standards.ieee.org/products-services/nesc/process.html for more information.</p>

 <p>IEEE Advancing Technology for Humanity</p>	Institute of Electrical and Electronics Engineers – www.ieee.org [Built Environment]
Document Name:	IEEE 1815: Standard for Electric Power Systems Communications-Distributed Network Protocol (DNP3)
ESS Relevance:	This document specifies the DNP3 protocol structure, functions, cyber security features and interoperable application options (subset levels). The specified subset level defines the functionality implemented in each device. The simplest level is intended for basic devices. More advanced levels support increasing functionality. The protocol is suitable for operation on a variety of communication media consistent with the makeup of most electric power communication systems.
Date of Current Edition:	2012
Date of Next Edition:	TBD (A new revision is not expected for several years)
Current Activity:	DNP3 Application Note AN2018-001 — DNP3 Profile for Communications with Distributed Energy Resources has been developed in partnership with the DNP Users Group, the MESA Standards Alliance, SunSpec Alliance, EnerNex, and Xanthus Consulting. This is a useful reference for ES systems that will communicate with utility SCADA using DNP3.0 protocol. See also IEEE 1815.1.

 IEEE <i>Advancing Technology for Humanity</i>	Institute of Electrical and Electronics Engineers – www.ieee.org [Built Environment]
Document Name:	IEEE 1547: Standard for Interconnection and Interoperability of Distributed Energy Resources with Associated Electric Power Systems Interfaces
ESS Relevance:	This is the Standard for interconnection of DER with electric power systems. DER as defined in IEEE 1547 includes energy storage DER systems capable of exchanging real power (kW, MW) with the local distribution utility grid. IEEE 1547 also defines the performance requirements that are the basis for UL 1741 listing.
Date of Current Edition:	2018
Date of Next Edition:	TBD (A new revision is not expected for several years)
Current Activity:	IEEE 1547 WG members have moved out to several '1547.X' working groups that are currently updating or creating new guides within the set of IEEE 1547 Standards (1547 and 1547.1) and the various supporting guides including P1547.9 for ES DER. For questions about IEEE 1547-2018, please contact the P1547Revision Chair, David Narang, at DNarang@NREL.gov

	International Society of Automation – www.isa.org [Built Environment]
Document Name:	ANSI/ISA-60079-0 (12.00.01-2013 Explosive Atmospheres – Part 0): Equipment-General Requirements
ESS Relevance:	This is part of a group of ANSI/ISA standards modified from IEC standards. This standard specifies the general requirements for construction, testing and marking of electrical equipment and Ex Components intended for use in potentially explosive atmosphere. Explosive atmospheres are identified and categorized by the National Electric Code ® ANSI/NFPA 70.
Date of Current Edition:	2013
Date of Next Edition:	N/A
Current Activity:	Need to investigate if any updates are planned.

	International Society of Automation – www.isa.org [Built Environment]
Document Name:	ANSI/ISA-TR12.13.01-1000 (R2013): Flammability Characteristics of Combustible Gases and Vapors
ESS Relevance:	This publication documents the available limit of flammability, autoignition and burning-rate data for more than 200 combustible gases and vapors in air and other oxidants, as well as empirical rules and graphs that can be used predict similar data for thousands of other combustibles under a variety of environmental conditions.
Date of Current Edition:	1999
Date of Next Edition:	N/A
Current Activity:	Need to investigate if any updates are planned.

	Modular Energy Storage Architecture Standards Alliance – www.mesastandards.org [Complete ESS]
Document Name:	MESA ESS Specification
ESS Relevance:	Standard addressing the communication architecture between a utility’s control system and the energy storage system (ESS).
Date of Current Edition:	December 2018
Date of Next Edition:	TBD
Current Activity:	Established goal to revisit with Alliance members in 2020/2021

	Modular Energy Storage Architecture Standards Alliance – www.mesastandards.org [Complete ESS]
Document Name:	MESA – PCS
ESS Relevance:	Standard that specifies standardized communication between components within the ESS.
Date of Current Edition:	March 2017 Document No. 12032 Version 2 (DRAFT)
Date of Next Edition:	TBD
Current Activity:	Established goal to revisit with Alliance members in 2020/2021

	National Electrical Contractors Association (NECA) – www.necanet.org [Codes and Complete ESS]
Document Name:	NECA 701: Standard for Energy Management, Demand Response and Energy Solutions
ESS Relevance:	This standard describes methods and procedures used for performing energy conservation surveys, controlling and maintaining energy consumption, implementing smart grid and demand response for residential, commercial and industrial ESS applications.
Date of Current Edition:	2013
Date of Next Edition:	TBD based on current activity
Current Activity:	Standard was developed to assist electrical contractors understand the emerging world of new energy storage applications when it was in its developing stages. The time may be soon that this standard should be revisited to determine what updates are needed.

	National Electrical Contractors Association (NECA) – www.necanet.org [ESS Installation]
Document Name:	NECA 417: Recommended Practice for Designing, Installing, Maintaining, and Operating Micro-grids
ESS Relevance:	The document is designed to improve communication among integrators, purchasers, and suppliers of electrical construction services and is intended to be referenced in contract documents for electrical construction projects. NECA 417 will cover the design, installation, maintenance, and operation of microgrids.
Date of Current Edition:	2019
Date of Next Edition:	TBD
Current Activity:	See http://www.neca-neis.org/ballot/fifth-ballot-for-creation-of-neca-417-201x-recommended-practice-for-designing-installing-operating-and-maintaining-microgrids for more information.

	National Electrical Manufacturers Association – www.nema.org [Complete ESS]
Document Name:	NEMA ESS 1: Standard for Uniformly Measuring and Expressing the Performance of Electrical Energy Storage Systems
ESS Relevance:	The Standard identifies general information and technical specifications relevant in describing an ESS. It also defines a set of test, measurement, and evaluation criteria which expresses the performance of electrical ESSs intended for energy-intensive and/or power-intensive stationary applications. There are eight ESS applications covered in this Standard including peak shaving, frequency regulation, islanded microgrids, PV smoothing, volt/VAR, renewables firming, power quality and frequency control.
Date of Current Edition:	2019
Date of Next Edition:	TBD
Current Activity:	Need to investigate if any updates are planned.

	National Electrical Manufacturers Association – www.nema.org [ESS Components]
Document Name:	NEMA 250: Enclosure for Electrical Equipment (1000V Maximum)
ESS Relevance:	This standard covers enclosures used to house electrical equipment not to exceed 1000V. It includes enclosures used in both indoor, outdoor and hazardous locations. It references adoption to requirements detailed in section 110.3(B) of NFPA 70.
Date of Current Edition:	2018
Date of Next Edition:	TBD
Current Activity:	TBD

	National Fire Protection Association (NFPA) – www.nfpa.org [Built Environment]
Document Name:	NFPA 70 : National Electrical Code (NEC)
ESS Relevance:	Article 706 (new in the 2017 edition) applies to energy storage systems and Article 480 remains applicable to batteries, in addition to other criteria in the NEC relevant to electrical equipment and installations. The NEC is made up of 18 Code Making Panels (CMP's). CMP 4 covers requirements for articles 690 for PV and 705 for Interconnections. CMP 13 covers requirements for articles 480 for batteries, and article 706 for ESS.
Date of Current Edition:	2020
Date of Next Edition:	2023
Current Activity:	<u>The document is open for Public Input until June 10, 2020.</u> See https://www.nfpa.org/codes-and-standards/all-codes-and-standards/list-of-codes-and-standards/detail?code=70&tab=nextedition for more information.

	National Fire Protection Association (NFPA) – www.nfpa.org [Built Environment]
Document Name:	NFPA 5000: Building Safety and Construction Code
ESS Relevance:	This code addresses those construction, protection and occupancy features necessary to minimize danger to life and property.
Date of Current Edition:	2018
Date of Next Edition:	2021
Current Activity:	The second draft report has been posted and the deadline for submitting a Notice of Intent to Make a Motion (NITMAM) has passed. See https://www.nfpa.org/codes-and-standards/all-codes-and-standards/list-of-codes-and-standards/detail?code=5000&tab=nextedition for more information.

	National Fire Protection Association (NFPA) – www.nfpa.org [Complete ESS]
Document Name:	NFPA 791: Recommended Practice and Procedures for Unlabeled Electrical Equipment
ESS Relevance:	Provides recommended procedures for evaluating unlabeled electrical equipment for compliance with nationally recognized standards. As such if an ESS were unlabeled, NFPA 791 could be used to evaluate the acceptability of an ESS. However, it should be noted that NFPA 791 does not cover procedures or evaluations relating to product certification systems that result in listed and/or labeled products.
Date of Current Edition:	2018
Date of Next Edition:	2021
Current Activity:	Changes to NFPA 791 that would foster its application to an ESS were submitted and considered by the NFPA 791 committee. Many of those changes were accepted. The period for submitting public comments closed in February. No NITMAMS were received so this standard should be available shortly after the 2021 NFPA Technical Session.

	National Fire Protection Association (NFPA) – www.nfpa.org [ESS Installation]
Document Name:	NFPA 855: Standard for the Installation of Stationary Energy Storage Systems
ESS Relevance:	<p>This is a recently released new standard that provides requirements to ensure the safety of energy storage systems including the new and emerging technologies. Chapters place an emphasis on electrochemical devices for energy storage systems (BESS). The standard provides limitations on maximum threshold quantities, capacities for a given system, space and separation limitations with breakdowns for specific energy storage system technologies. Requirements for commissioning, operations and maintenance, decommissioning of systems with information for AHJ's and first responders is also detailed.</p>
Date of Current Edition:	2020
Date of Next Edition:	2023
Current Activity:	<p>This first edition (2020) was published in August 2019. Certified Amending Motions (CAMS) were submitted at the last NFPA General Meeting Technical Session requesting exemption from the scope of the standard for utilities as well as a revision in the proposed scope to exempt lead-acid and ni-cd batteries. Due to floor action and follow-up at the Standards Council review meeting, the Standards Council made the decision to revert to previous language. The net effect for a First Edition (with no previous language), is that the standard is published with a "Reserved" scope since no previous language exists.</p> <p>Pre-first draft meetings have begun for the 2023 revision, and the document is open for Public Input until June 30, 2020. https://www.nfpa.org/codes-and-standards/all-codes-and-standards/list-of-codes-and-standards/detail?code=855&tab=nextedition</p>

	National Fire Protection Association (NFPA) – www.nfpa.org [ESS Installation]
Document Name:	NFPA 78: Guide on Electrical Inspections
ESS Relevance:	<p>This new standard covers the minimum criteria to aid in organizing and conducting electrical inspections, including administrations, plan review and field inspections. This applies to new as well as modifications to existing electrical installations, including energy storage systems.</p>
Date of Current Edition:	2020
Date of Next Edition:	2024
Current Activity:	<p>The document is open for public input until June 1, 2021. See https://www.nfpa.org/codes-and-standards/all-codes-and-standards/list-of-codes-and-standards/detail?code=78&tab=nextedition for more information. Note: both NFPA 78 and NFPA 1078 Committee and Staff Liaison are the same.</p>

	National Fire Protection Association (NFPA) – www.nfpa.org [Reference Item]
Association Name:	National Fire Protection Association (NFPA)
ESS Relevance:	One of the main safety codes organizations focused on all aspects of safety, especially fire safety. Owner of a potpourri of codes and standards applicable to energy storage and energy storage systems. Major ones of current interest are NFPA 855, NFPA 1, NFPA 75 and NFPA 76 as well as the most recognized National Electric Code (NFPA 70).
Date of Next Meeting:	The NFPA General Meeting originally scheduled for June in Orlando FL has been cancelled due to the COVID virus. A possible virtual meeting is under planning consideration.
Current Activity:	Various aspects of the General Meeting include the Technical Meeting Session where revised standards/codes are balloted and TIA's/CAM's are presented.

	Underwriters Laboratories (UL) – https://ulstandards.ul.com/develop-standards/ [Complete ESS]
Document:	ANSI/CAN/UL 9540: Energy Storage Systems and Equipment
ESS Relevance:	Product safety standard for an energy storage system.
Date of Current Edition:	February 2020
Date of Next edition:	TBD – UL standards are under continuous maintenance and are updated as warranted.
Current Activity:	<p>The 2nd Edition of ANSI/CAN/UL 9540 was published on February 27, 2020. The published standard can be purchased or Digitally Viewed from: https://www.shopulstandards.com/ProductDetail.aspx?UniqueKey=36788</p> <p>Appendix D addresses specific testing requirements for lead-acid and nickel cadmium batteries. There is currently an ESSB/UL Task Force reviewing the latest version of Appendix D to confirm listing requirements for lead-acid and ni-cd batteries. The intent is to provide a pragmatic set of test requirements that satisfy the actual risks associated with these two battery types.</p>

	Underwriters Laboratories (UL) – https://ulstandards.ul.com/develop-standards/ [Complete ESS]
Document Name:	UL 9540A: Test Method for Evaluating Thermal Runaway Fire Propagation in Battery Energy Storage Systems (BESSs)
ESS Relevance:	This test method evaluates the fire characteristics of a battery energy storage system that undergoes thermal runaway. The data generated can be used to determine the fire and explosion protection required for an installation of a battery energy storage system.
Date of Current Edition:	Nov 2019 (January 2020 w/ CRD)
Date of Next edition:	TBD – UL standards are under continuous maintenance and are updated as warranted
Current Activity:	<p>The 4th Edition of ANSI/CAN/UL 9540A was published on November 12, 2019. The published standard can be purchased or Digitally Viewed from: https://www.shopulstandards.com/ProductDetail.aspx?UniqueKey=36503</p> <p>A CRD (certification requirement decision) was published in January 2020 covering corrections to gas measurement methods to make FTIR as an option for measuring hydrocarbon contents of gas emissions and to include Hydrogen measurements during the Unit Level Test. These changes have also been submitted as proposals to the next Edition of UL 9540A and will be sent out for review and comment in CSDS in the future. e https://csds.ul.com/Home/ProposalsDefault.aspx to watch for future proposal activity for UL 9540A.</p>

	Underwriters Laboratories (UL) – https://ulstandards.ul.com/develop-standards/ [ESS Components]
Document Name:	UL 62133-2: Secondary Cells and Batteries Containing Alkaline or Other Non-Acid Electrolytes - Safety Requirements for Portable Sealed Secondary Cells, and for Batteries Made from Them, for Use in Portable Applications - Part 2: Lithium Systems
ESS Relevance:	<p>UL 62133-2 is a binational, IEC based standard that specifies requirements and tests for the safe operation of portable sealed secondary lithium cells and batteries containing non-acid electrolyte for lithium systems for Canada and the US. This standard is not, by itself, generally suitable for the evaluation of the safety of end-products, as it lacks specific requirements regarding charging, the effect of normal loads, abnormal conditions that should be considered, and the physical and electromagnetic stresses encountered in the anticipated environment of the end-product.</p> <p>NOTE Battery packs with additional features or circuitry, including integral circuitry that facilitates charging, are considered to be end-products. This standard deals with the covered components used in accordance with CAN/CSA-C22.2 No. 0.</p>
Date of Current Edition:	January 2020
Date of Next Edition:	Need to investigate if any updates are planned.
Current Activity:	The 1st edition of UL 62133-2 was published January 10, 2020. See https://www.shopulstandards.com/ProductDetail.aspx?UniqueKey=36642 for more information on the published standard.

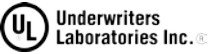
	Underwriters Laboratories (UL) – https://ulstandards.ul.com/develop-standards/ [ESS Components]
Document Name:	ANSI/UL 810A: Electrochemical Capacitors
ESS Relevance:	Addresses the safety of electrochemical capacitors, which can be used as an energy source in energy storage systems.
Date of Current Edition:	The first edition of the standard was reaffirmed via a CSDS bulletin on February 3, 2017 and approved by ANSI on March 28, 2017.
Date of Next Edition:	TBD – UL standards are under continual maintenance and are updated as warranted.
Current Activity:	None at Present

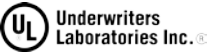
	Underwriters Laboratories (UL) – https://ulstandards.ul.com/develop-standards/ [ESS Components]
Document Name:	UL 1642: Lithium Batteries
ESS Relevance:	This standard cover lithium batteries intended for use in technician-replaceable or use-replaceable applications. Purpose is to reduce the risk of fire or explosion when Lithium batteries are used in a product. The standard imposes limits as to the amount of lithium contained in a battery that is covered by this standard without additional testing requirements.
Date of Current Edition:	2012 with revision June 2015.
Date of Next Edition:	TBD – UL standards are under continual maintenance and are updated as warranted.
Current Activity:	Three topics were balloted June 2019: (1) Proposed new requirements for soft-case prismatic cells, (2) Clarification of Projectile Test set-up, and (3) Revision of Coin Cell warning marking. Topic 1 has failed and forwarded to a Task Group for further development. Topic 2 will be recirculated to propose additional changes. Topic 3 achieved consensus and will be published once Topic 2 has been recirculated. This is based on the latest information we have at this moment of publication. See https://standardscatalog.ul.com/standards/en/standard_1642_5 for information regarding this standard.

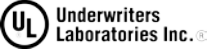
	Underwriters Laboratories (UL) – https://ulstandards.ul.com/develop-standards/ [ESS Components]
Document Name:	UL 1741: Inverters, Converters, Controllers and Interconnection System Equipment for Use with Distributed Energy Resources
ESS Relevance:	This standard covers requirements for inverters, converters, charge controller and interconnection system equipment (ISE) intended for use in both off-grid and grid-connected environments. Recent (2018) revision adds information that clarifies intention to supplement IEEE 1547 and IEEE 1547.1.
Date of Current Edition:	2018
Date of Next Edition:	TBD – UL standards are under continual maintenance and are updated as warranted.
Current Activity:	<p>Revisions contained in the second edition address rapid shutdown to better align UL 1741 with the Standard for Photovoltaic (PV) Module Safety Qualification - Part 1: Requirements for Construction, UL 61730-1.</p> <p>A Preliminary Review Proposal was issued in November 2019 detailing new requirements for Grid Support Utility Interactive Interoperability Optional Functions: Prevent Enter Service and Limit Active Power (CA Rule 21, Phase 3, functions 2 and 3). Comments were received and are being considered.</p>

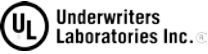
	Underwriters Laboratories (UL) – https://ulstandards.ul.com/develop-standards/ [ESS Components]
Document Name:	ANSI/CAN/UL 1973: Standard for Batteries for Use in Stationary, Vehicle Auxiliary Power and Light Electric Rail (LER) Applications
ESS Relevance:	This standard covers requirements for battery systems for use as Energy Storage for stationary applications such as PV, wind turbine storage or UPS. Also covers battery systems for use in light rail and stationary rail applications such as rail substations. Two appendixes are specific to newer emerging technologies: [1] Appendix B – sodium-beta type batteries and [2] Appendix c to flowing electrolyte batteries.
Date of Current Edition:	2018
Date of Next Edition:	TBD – UL standards are under continual maintenance and are updated as warranted.
Current Activity:	A Call for Proposals for UL 1973 was sent out to Standard Technical Panel (STP) members and standard subscribers. Numerous proposals were received and are being included in a preliminary review document that will be sent out for comment to the STP and standard subscribers in the future. See https://csds.ul.com/Home/ProposalsDefault.aspx for future preliminary review proposal activity for UL 1973. Note: Currently there is no listing for UL 1973.

	Underwriters Laboratories (UL) – https://ulstandards.ul.com/develop-standards/ [ESS Components]
Document Name:	ANSI/CAN/UL 1974: Evaluation for Repurposing Batteries
ESS Relevance:	<p>This standard covers the sorting and grading process of battery packs, modules and cells, as well as electrochemical capacitors that were originally configured and used for other purposes, such as electric vehicle (EV) propulsion, and now are intended for a repurposed use application, such as for use in stationary energy storage systems and other applications. The requirement is essentially to determine their state of health for continued viability and the rating mechanisms the repurposing manufacturer may use for those that are determined suitable for continued use in these applications.</p>
Date of Current Edition:	2018
Date of Next Edition:	TBD – UL standards are under continual maintenance and are updated as warranted.
Current Activity:	Need to investigate if any updates are planned. See https://www.shopulstandards.com/ProductDetail.aspx?UniqueKey=35079 for more information on the published standard.

	Underwriters Laboratories (UL) – https://ulstandards.ul.com/develop-standards/ [ESS Components]
Document Name:	UL 2580, Batteries for Use in Electric Vehicles
ESS Relevance:	<p>This standard covers electrical energy storage assemblies such as battery packs and combination battery pack-electrochemical capacitor assemblies and the subassembly/modules that make up these assemblies for use in electric-powered vehicles. The requirements evaluate the electrical energy storage assembly's ability to safely withstand simulated abuse conditions and prevents any exposure of persons to hazards as a result of the abuse. This standard evaluates the electric energy storage assembly and modules based upon the manufacturer's specified charge and discharge parameters at specified temperatures. UL 1974 references UL 2580 for battery construction and cell safety requirements.</p>
Date of Current Edition:	2nd edition ANSI approved June 2016
Date of Next Edition:	TBD – UL standards are under continual maintenance and are updated as warranted.
Current Activity:	<p>This standard is a Joint Binational Standard with ULC. Proposed revisions were recirculated with comments due and received in September 2019. A number of revisions are being considered and a published Joint 3rd edition of ANSI/CAN/UL/ULC 2580 is expected in 2020. See https://www.shopulstandards.com/ProductDetail.aspx?UniqueKey=35420 for more information on the proposal out for ballot and comment.</p>

	Underwriters Laboratories (UL) – https://ulstandards.ul.com/develop-standards/ [Reference Item]
Association Name:	United Underwriters Laboratories is a non-profit affiliate of UL, Inc.
ESS Relevance:	Responsible for 10 of the ESS related standards listed in this report. UL 9540 and UL 9540A become the bedrock testing standards for all BESS and ESS related safety assurances for batteries and emerging technologies installed in systems.
Date of Next Meeting:	United Underwriter Laboratories does not conduct a general meeting, nor does it hold regular meetings with the various standards development efforts. Instead, they employ Standards Technical Panels (STP's) to act as de facto Working Groups to review inputs from comments received when standards could stand revision or updating. As pointed out in the UL standards listed above, UL standards are under continuous maintenance and are updated as warranted.
Current Activity:	See standards activities above.

ENERGY STORAGE C/S SAFETY COLLABORATIVE STANDARDS DEVELOPMENT ORGANIZATIONS (SDO's)						
ORGANIZATION	Built Environment	Complete ESS	ESS Installations	ESS Components	Reference Items	SDO Website¹
ASHRAE			1			www.ashrae.org
ASME		2			1	www.asme.org
CSA			1	1		www.csagroup.org
DNV-GL		1				www.dnvgl.com
FM Global		1			1	www.fmglobal.com
ICC	4					www.iccsafe.org
IEEE-ESSB	1		1	3	1	https://cmte.ieee.org/pes-essb/
IEEE-NESC	1					https://standards.ieee.org/products-services/nesc/index.html
IEEE-SCC 18	1					https://sagroups.ieee.org/scc18/
IEEE-SCC21	1					www.ieee.org
ISA	2					www.isa.org
MESA		2				www.mesastandards.org
NECA		1	21			https://necanet.org/
NEMA		1		1		www.nema.org
NFPA	2	1	2		1	www.nfpa.org
UL		2		7	1	https://ulstandards.ul.com/
46	12	11	6	12	5	
	30%	20%	16%	24%	10%	

Every effort is made by the Pacific Northwest National Laboratory (PNNL) and Sandia National Laboratories (SNL) staff to ensure the accuracy of the information presented in this report. SNL and PNNL very much appreciate the input from the standards developing organizations (SDOs) covered in the report as well as contributing volunteers who may be involved in one or more of the SDO initiatives covered in this document. We acknowledge that there may be standards/codes that exist but not included in this report. Suggestions for revision, additions, and enhancements to this document are welcome and encouraged.

On behalf of the U.S. Department of Energy, Office of Energy and Energy Storage System Program, whose support has made this report possible, we hope this document serves as a primary source of information about codes and standards related to ESS safety. Not all safety codes may be listed, but with your help we can continue to include those codes or standards that are meaningful. This will allow us to achieve the objectives outlined in the ESS Safety Roadmap as well as fostering confidence in the safety and reliability of Energy Storage Systems. For more information about the ESS Safety Roadmap efforts visit <http://www.sandia.gov/ess/>. For questions related to or to provide input on this document, please contact chris.searles@baebatteriesusa or matthew.paiss@pnnl.gov

At PNNL, our mission is to transform the world through courageous discovery and innovation. It is our vision that PNNL science and technology inspires and enables the world to live prosperously, safely, and securely.

Sandia National Laboratories is a multimission laboratory managed and operated by National Technology & Engineering Solutions of Sandia, LLC, a wholly owned subsidiary of Honeywell International Inc., for the U.S. Department of Energy's National Nuclear Security Administration under contract DE-NA0003525.



**PNNL-29901
SAND2020-4889 R**



Contact Information

For more information about this document and/or ES Safety Collaborative activities, contact:

Chris Searles

Consulting Liaison for Sandia National Laboratories

P.O. Box 5800 MS 0613

Albuquerque, NM87185-0613

Phone: 214-850-1183

Email: chris.searles@baebatteriesusa.com



Contact Information

For more information about this document and/or ES Safety Collaborative activities, contact:

Matthew Paiss

Pacific Northwest National Laboratory

P.O. Box 999, MSIN K2-44

Richland, WA 99352

Phone: 831-566-3057

Email: matthew.paiss@pnnl.gov