



*Exceptional service in the national interest*

# SANDIA ENERGY STORAGE ANALYTICS – FY25 UPDATES

*Presented by Tu Nguyen*



*2025 DOE OE Energy Storage Peer Review*

*Presentation ID: 504*



Sandia National Laboratories is a multimission laboratory managed and operated by National Technology and Engineering Solutions of Sandia LLC, a wholly owned subsidiary of Honeywell International Inc. for the U.S. Department of Energy's National Nuclear Security Administration under contract DE-NA0003525.

# ENERGY STORAGE ANALYTICS – PROGRAM ALIGNMENT



- **Project Goal:** develop practical methods and tools to understand, plan, and operate energy storage systems so they can make the electric grid more reliable and cost-effective.
- **Current Practice:** utilities and developers currently rely on simplified models or proprietary tools that don't capture the full technical and economic value of storage. This leads to limited insight into where and how storage can provide the most benefit.
- **Why Sandia:** Sandia combines deep expertise in energy storage testing, modeling, and grid planning with the ability to develop and release open-source tools, enabling broad adoption across the energy industry.
- **Innovation:** We transform complex energy storage research into practical tools and methods by combining real-world test data, advanced modeling, and grid-focused control strategies. By making these tools publicly accessible, we enable all stakeholders to evaluate and deploy storage with higher confidence and efficiency.
- **Impact:** our work will help the stake holders make better investment and operational decisions, leading to a more reliable and efficient grid and lowering costs for consumers.
- **Alignment:** this work supports DOE Office of Electricity goals to enhance grid reliability, resilience, and flexibility, aligning with the administration's focus on modernizing U.S. infrastructure and supporting a secure, affordable energy system.



# ENERGY STORAGE ANALYTICS - OVERVIEW



## Sandia's Energy Storage Analytics *includes four main areas*

1

### **Energy storage modelling and evaluation**

Develop and validate energy storage models using large sets of testing and operational data of ESSs. Perform techno-economic studies that comprehensively investigate the economic and technical benefits of ESSs in a variety of applications.

2

### **Grid reliability and planning**

Develop frameworks and models for grid planning incorporating state-of-the-art energy storage models

3

### **Energy storage control**

Develop control framework for grid energy storage to improve grid resilience, reliability while delivering the maximum benefits.

4

### **Software tools development**

Further develop analytical and control frameworks into software tools that are made publicly available. The intent is to remove technical barriers for all stakeholders in analyzing energy storage systems.

# ENERGY STORAGE MODELLING AND EVALUATION

# COMPUTATIONALLY TRACTABLE BATTERY DEGRADATION MODELS FOR OPTIMIZATION AND CONTROL



**Objective:** Develop data-driven surrogate models to capture battery degradation mechanism in a computationally efficient manner

**Team:** Ujjwol Tamrakar, Hyungjin Choi (Sandia National Labs)  
Erfan Kharazian, Amarsagar Reddy (Arizona State University)

## Why is the work needed?

- Need to incorporate **accurate models** that capture the degradation to balance the cost of battery degradation and optimal performance in **real-time**
- Current physics-based models are computationally intractable for real-time optimization and control

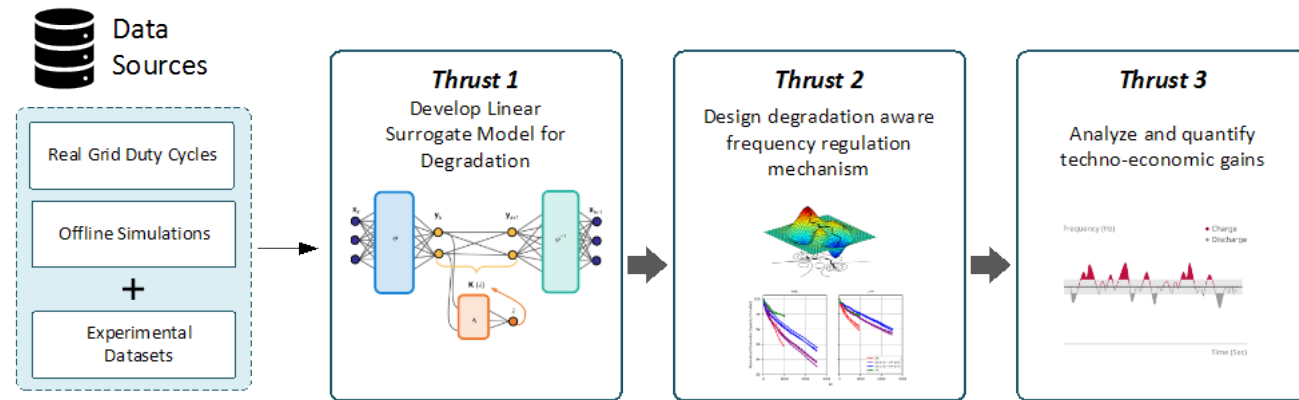

## Proposed Methodology

## What we do?

- Develop data-driven surrogate models that describe the degradation dynamics yet are computationally tractable
- Incorporate battery degradation into analysis, optimization, and control design

# COMPUTATIONALLY TRACTABLE BATTERY DEGRADATION MODELS FOR OPTIMIZATION AND CONTROL



## • What is the progress?

- Developed code to run PyBaMM simulations and generate training data based on frequency regulation signals
- Preliminary machine-learning model developed to learn battery states
- Abstract summarizing preliminary results accepted at the IEEE EESAT 2026 conference

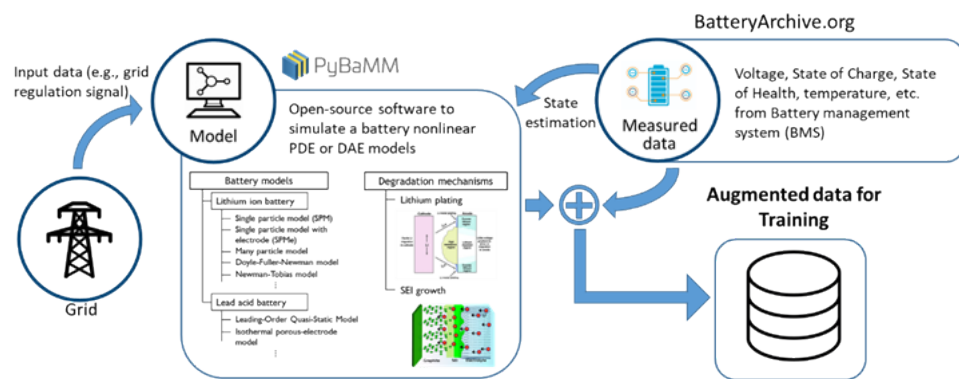

**Data Generation for Training**

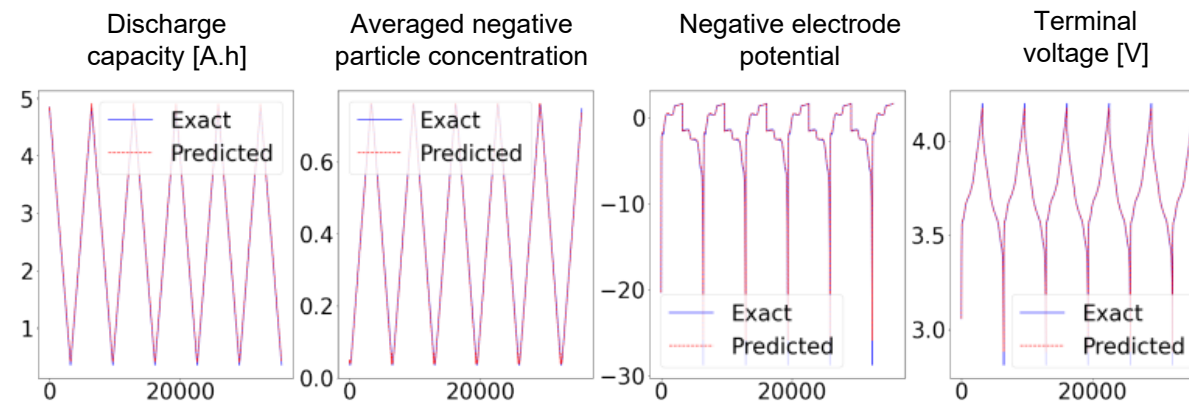

**Preliminary Results**

## • What are the next steps?

- Extend the existing work on data-driven modeling to **incorporate battery degradation** dynamics
- Combine data-driven model into frequency regulation formulation
- Show effectiveness of control performance and economic benefits of integrating degradation surrogate models.

# GRID RELIABILITY AND PLANNING





# GRID RELIABILITY AND PLANNING



**Objective:** Develop frameworks and models for grid planning incorporating state-of-the-art energy storage models

## Why is the work needed?

ESS have unique characteristics and modeling challenges

-  Energy limited nature
-  Degradation, replacement costs, asset lifetimes
-  Temporal resolution of planning framework
-  Operation strategies
-  Technology-specific model characteristics



## What we do?

Develop a toolbox for integrated grid planning with state-of-the-art ESS models

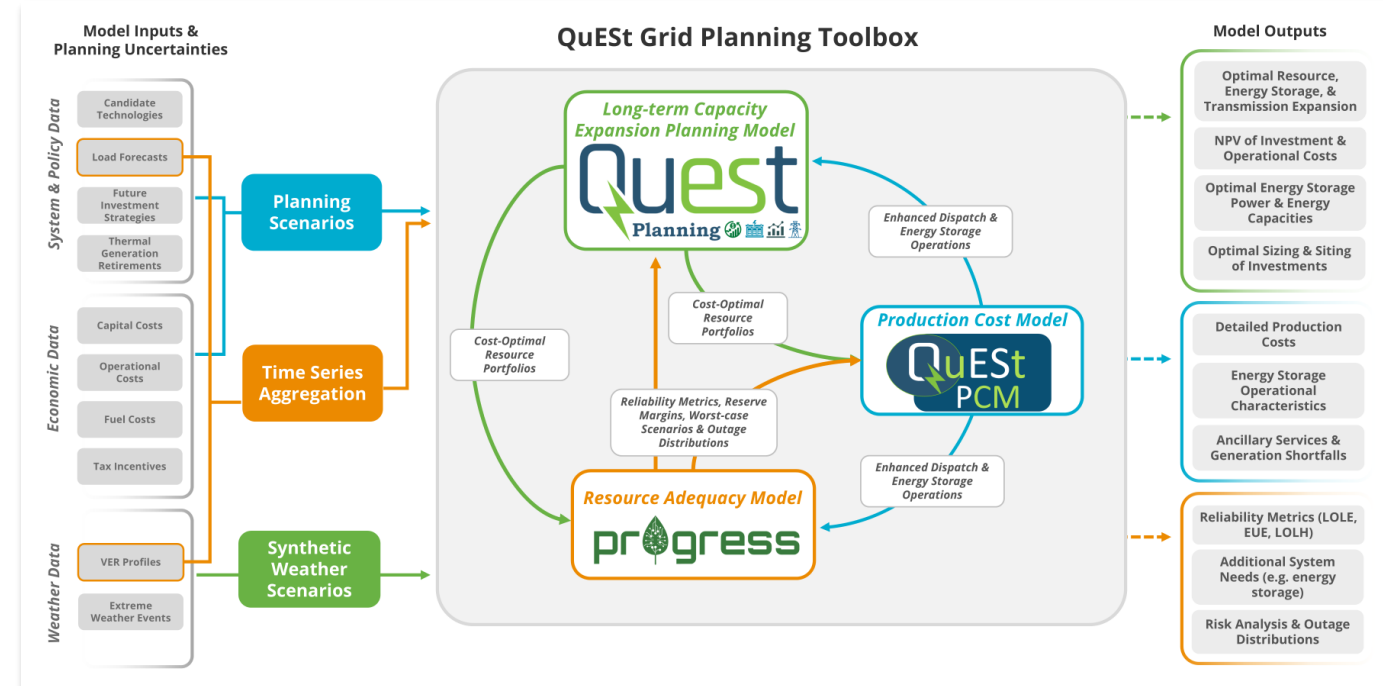

Improved grid planning tools enable well-informed investment and operational decisions

# LONG-TERM CAPACITY EXPANSION PLANNING FOR ENERGY STORAGE SYSTEMS & MODELING FLEXIBILITY



**Objective:** Develop **long-term capacity expansion planning (CEP)** model focused on energy storage systems (ESS) to ensure **cost-optimal** and **reliable** ESS, generation, and transmission investments over a long-term planning horizon

**Team:** Cody Newlun, Dilip Pandit, Atri Bera, Yung-Jai Pomeroy, Andres Lopez, Ray Byrne, Tu Nguyen

## Why is the work needed?

- ESSs dominate interconnection queues and there is a need to improve **ESS modeling in open-source CEP** models
- Need to better characterize **uncertainties** to identify cost-optimal ESS, generation, and transmission investments
- Ensure **reliability criterion** is met while co-optimizing ESS, generation, and transmission investments in the CEP

## What do we do? (2 major thrusts)

### 1. Open-source tool development:

- QuEst Planning** provides user defined **model flexibility**: **spatio-temporal scope, scenarios & long-term uncertainties** (e.g. capital costs), **investment candidates**
- Collaborate with utilities for industry-based research (e.g. Public Service Company of New Mexico)
- QuEst Planning provides a **user friendly GUI** and **command-line scripts** to enable model design, scenario generation, and enhanced results viewer & scenario comparison
- Model a **broad range of ESS** technologies to optimally site & size ESS onto transmission network

### 2. Research thrusts: improving reliability analysis and transmission planning in CEP

- Deploy iterative MIP to evaluate **reliability** of incumbent solutions and present reliability cuts for years with reliability index violations
- Assess **tradeoffs** of modeling assumptions and interregional transmission investments with ESSs (in-progress)

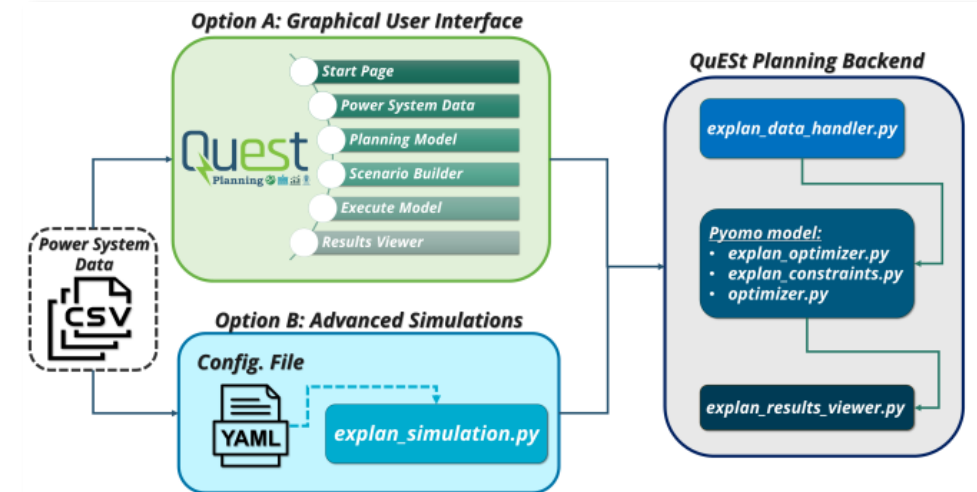

# LONG-TERM CAPACITY EXPANSION PLANNING FOR ENERGY STORAGE SYSTEMS & MODELING FLEXIBILITY



## Progress (FY25 Project Updates)

- Open-source python package released on Sandia Labs GitHub ([v 1.0.0](#)) & QuEST 2.0 platform
- Enhanced visualizations** via GUI including: improved mapping software, interactive results viewer, and scenario comparison dashboard
- Development of framework for **reliability-constrained CEP**
- EESAT 26** abstract accepted; conference paper to follow
- Moderated panel on ESS modeling at **2025 IEEE PES General Meeting**
- ESS Modeling Best Practices** briefing written for the Michigan Public Service Commission
- QuEST Planning [documentation](#) created on Github pages

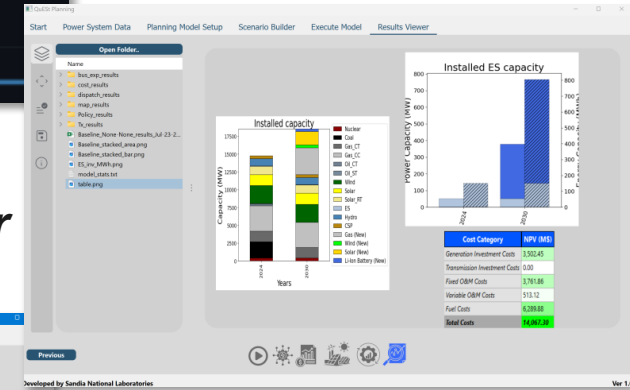
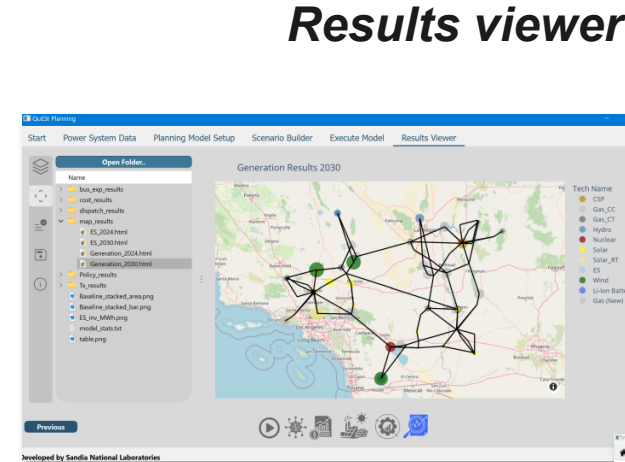

Interactive mapping software

## Future work

- Conduct case study analyzing **interregional transmission** and **ESS** investment tradeoffs
- Perform case study for US power systems to determine role of ESS in delivering **affordable and reliable** investment portfolios— consider *load growth due to data centers, nuclear energy, and firm capacity retirements*
- Develop integrated workflow for **QuEST Planning, ProGRESS, and QuEST PCM** via QuEST Workspace
- Write a journal paper on modeling ESS in planning models

Scenario comparison dashboard

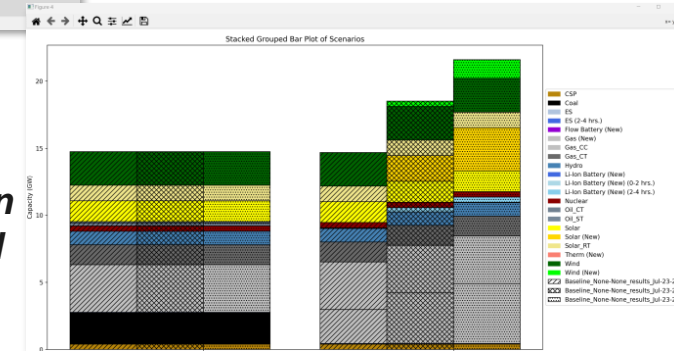

# ENHANCING GRID RELIABILITY USING ENERGY STORAGE SYSTEMS



**Objective:** Develop frameworks for enhancing grid reliability using energy storage systems.

**Team:** Atri Bera, Dilip Pandit, Cody Newlun, Andres Lopez, Yung-Jai Pomeroy, Tim Wilcox, Tu Nguyen, Ray Byrne

- **Why is the work needed?**

- Energy storage systems widely deployed for **grid reliability applications** including mitigating uncertainties, providing flexibility, serving as back-up power
- Crucial to accurately model ESS **failure and operational characteristics** in grid reliability studies to understand contribution of these flexible resources
- Current frameworks *generalize cell degradation models* to system-level capacity fade
- Uncertainties due to *unreliable non-dispatchable resources* not fully captured by current tools

This project has **two** main objectives: 1) Develop **open-source grid reliability assessment tool** with advanced ESS models, 2) Develop a probabilistic failure model for grid-connected BESS that considers cell-cell capacity variation and impact of battery topology on system capacity fade

# ENHANCING GRID RELIABILITY USING ENERGY STORAGE SYSTEMS



**Objective:** Open-source grid reliability assessment tool development

## What we do?

- Develop an open-source grid reliability assessment tool for evaluating the reliability of the power grid integrated with ESS — *Probabilistic Grid Reliability Analysis with Energy Storage Systems (ProGRESS)*
- Develop and incorporate state-of-the-art *ESS failure and operation models* for accurately evaluating the contribution of ESS toward enhancing grid reliability
- Collaborate with New Mexico utility PNM for testing and benchmarking tool

## Progress

- Released ProGRESS v1.0 in December 2024 and [v1.2.0](#) in June 2025 with new features, GUI improvements, and bug fixes on GitHub
- Full API reference and user documentation published on GitHub pages
- Paper on ProGRESS models presented at 2025 IEEE EESAT conference

## Next Steps

- Incorporate various *ESS operation modes* in ProGRESS including economic, reliability, and stacked applications
- Integrate ProGRESS with other QuEST tools — QuEST Planning and PCM for *integrated grid planning with ESS*
- Perform case study for US systems to determine role of ESS in delivering **affordable and reliable power** to customers — consider *load growth due to data centers, nuclear energy, and firm capacity retirements*

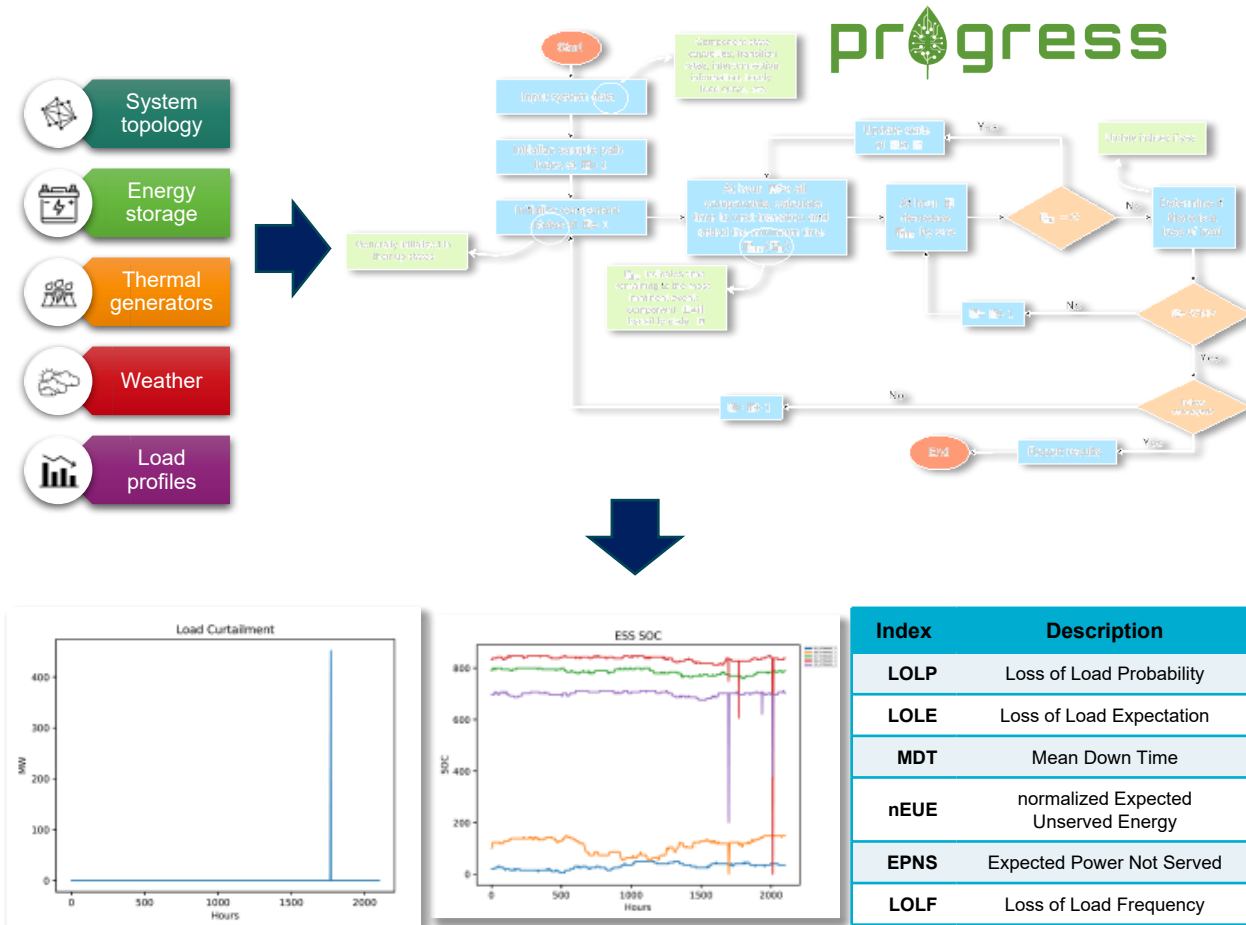

# ENERGY STORAGE CONTROL

# ENERGY STORAGE CONTROLS



*“Develop control strategies for grid energy storage to improve and enhance grid resilience, reliability, and security.”*

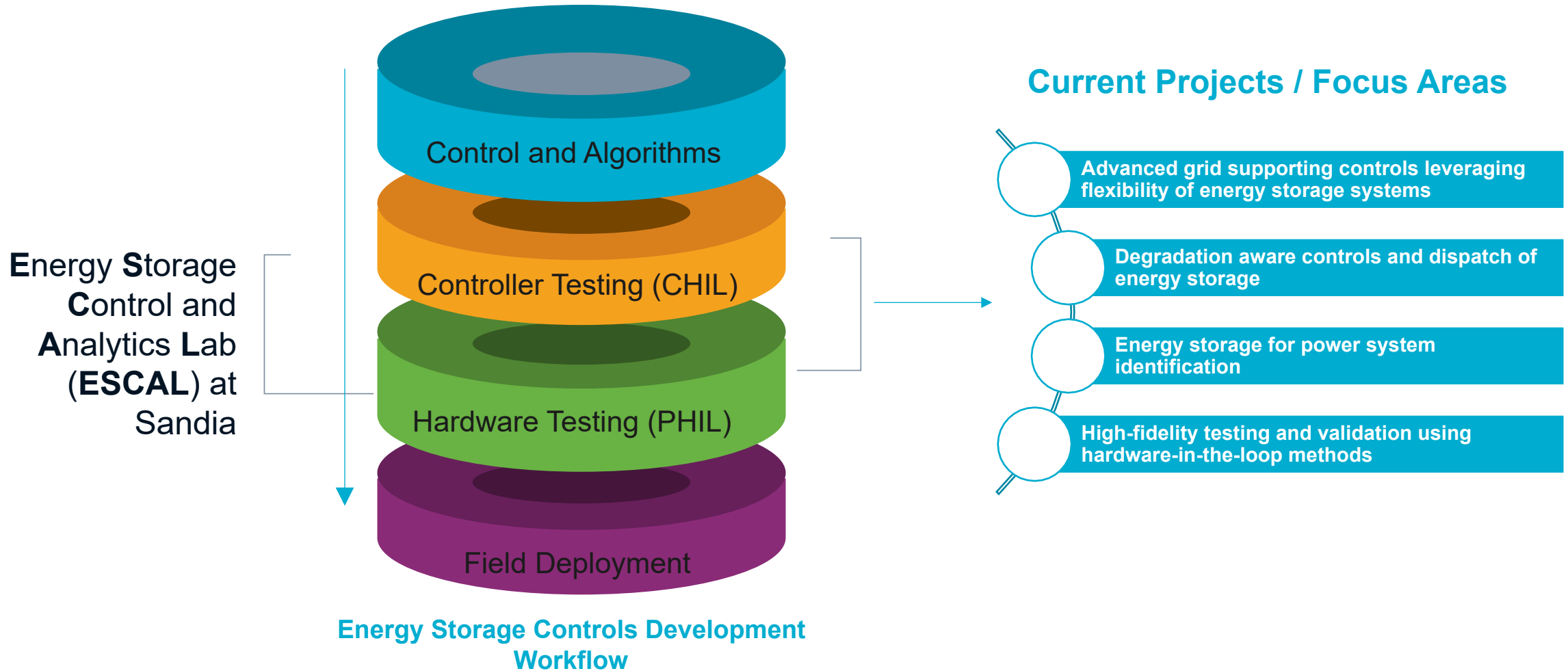

CHIL : Controller-Hardware-in-the-Loop  
PHIL : Power-Hardware-in-the-Loop

# HARDWARE IN THE LOOP DESIGN AND TESTING PLATFORM

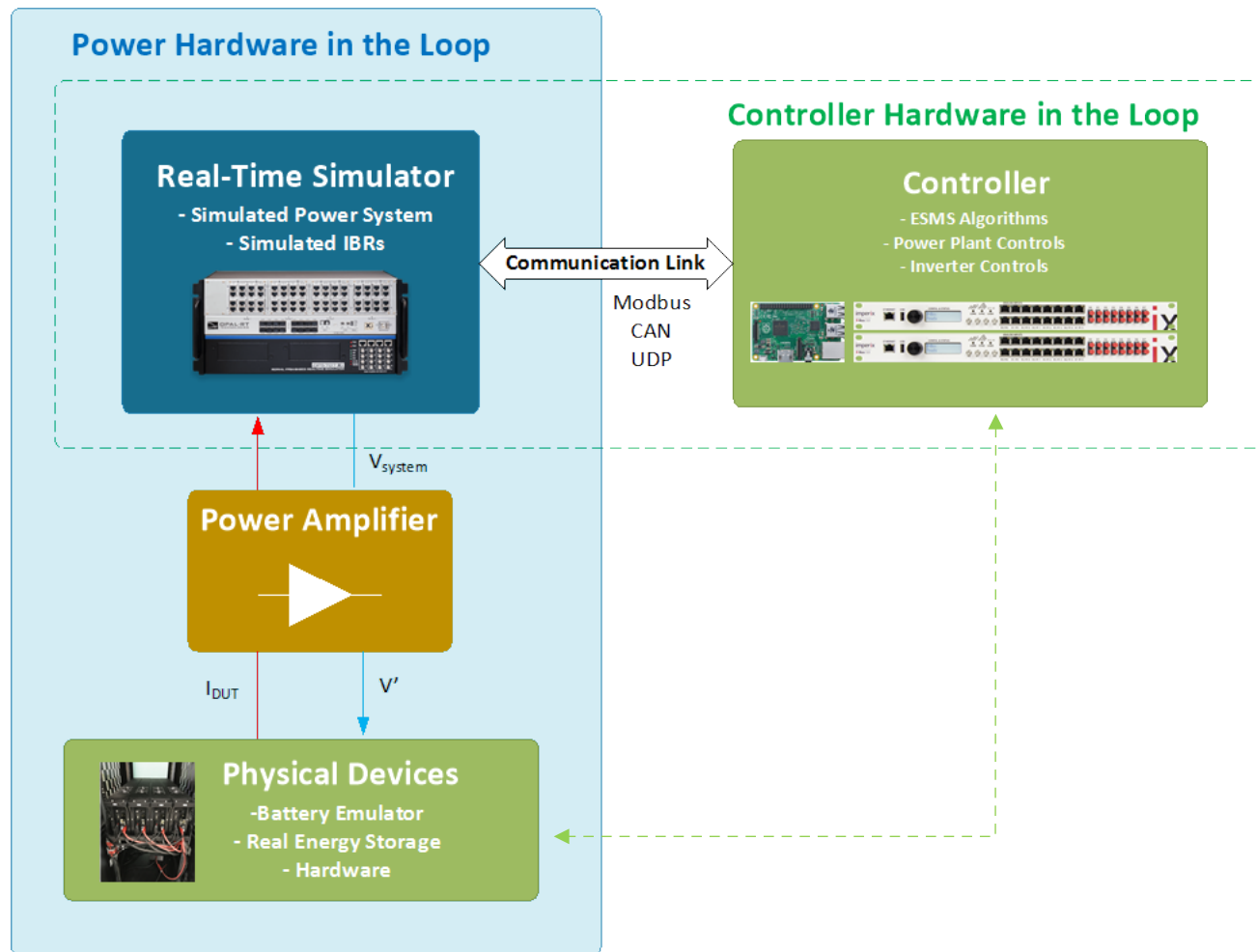

1

## ESMS and Control Testing

Design and testing of novel ESMS algorithms and inverter control techniques

2

## Grid Modeling

Design and testing in conjunction with high fidelity grid models, IBR and energy storage models

3

## Physical Devices

Realistic validation with battery emulators and real energy storage hardware

4

## Code Generation

Generate and test python/ C-code for energy storage controls

5

## Communication

Test energy storage controls incorporating of communication delays and latencies

**Hardware-in-the-Loop Capabilities at ESCAL  
in Sandia National Labs**



# HIGH-FIDELITY CONTROLLER HARDWARE-THE-LOOP (CHIL) PLATFORM FOR DESIGN AND TESTING OF ENERGY STORAGE CONTROL STRATEGIES

**Objective:** Develop a high-fidelity simulation environment for design and testing of energy storage controls for grid applications

**Team:** Niranjan Bhujel, Ujjwol Tamrakar, Tu A. Nguyen

## • Why is the work needed?

- Energy storage controls design and testing limited to low-fidelity simulation environments
- Difficult to quantify the technical performance and practicable applicability

## • What we do?

- Develop **high-fidelity testing framework to validate energy storage control**
- Increase fidelity of grid and energy storage models
- Study impacts of code-generation, computational and communication delays on control performance
- Leverage real-time simulators and hardware-in-the-loop methods

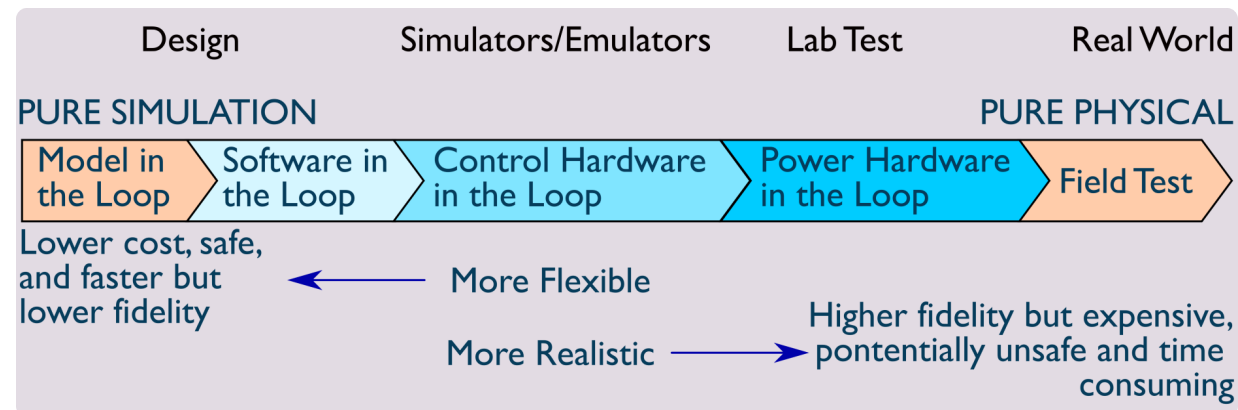



# HIGH-FIDELITY CONTROLLER HARDWARE-THE-LOOP (CHIL) PLATFORM FOR DESIGN AND TESTING OF ENERGY STORAGE CONTROL STRATEGIES

## • What is the progress?

- CHIL framework developed
  - Grid, storage can be modeled in detailed including BMS
  - C-code generation for energy storage controls
- Developed case studies to demonstrate impact of BMS on storage controls
- Preliminary results submitted to the IEEE ECCE 2025 conference

## • What are the next steps?

- Increasing fidelity by incorporating additional aspects of BMS (thermal management, cell balancing)
- Develop more case studies to illustrate impact of BMS and storage models on grid applications
- Expanding framework for different storage technologies

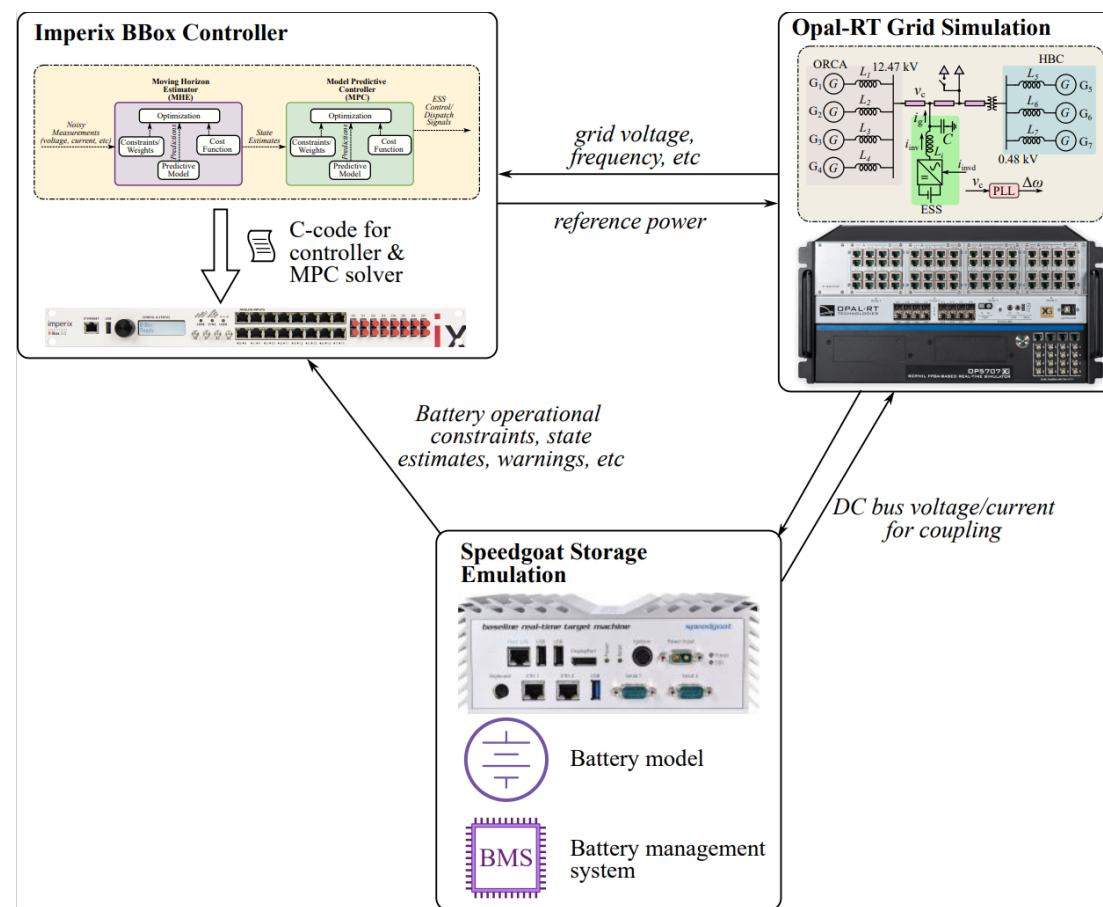

**Proposed CHIL Framework**

# ENERGY STORAGE CONTROL – GENERALIZED SYNCHRONOUS MACHINE ARCHITECTURE



**Objective:** Develop advanced control strategies for energy storage that enhance grid stability, increase flexibility, and enable seamless integration into grids with varied compositions.

Team: Ryan Elliott, Hyungjin Choi, Dan Trudnowski (Montana Tech)

## • Why is the work needed?

- Traditional storage inverters utilize controls that rely on tracking the grid voltage angle, which often fails during faults, disconnecting batteries from the grid.
- Current grid-forming strategies, such as droop and virtual synchronous machine (VSM) control, are rigid and difficult to integrate at high penetrations.
- These existing methods can adversely interact with grid resources and controls, potentially driving oscillations against conventional generation.

## • What's new in our approach?

- We've developed a *generalized* control architecture that offers unique capabilities by integrating and unifying both droop and VSM controls.

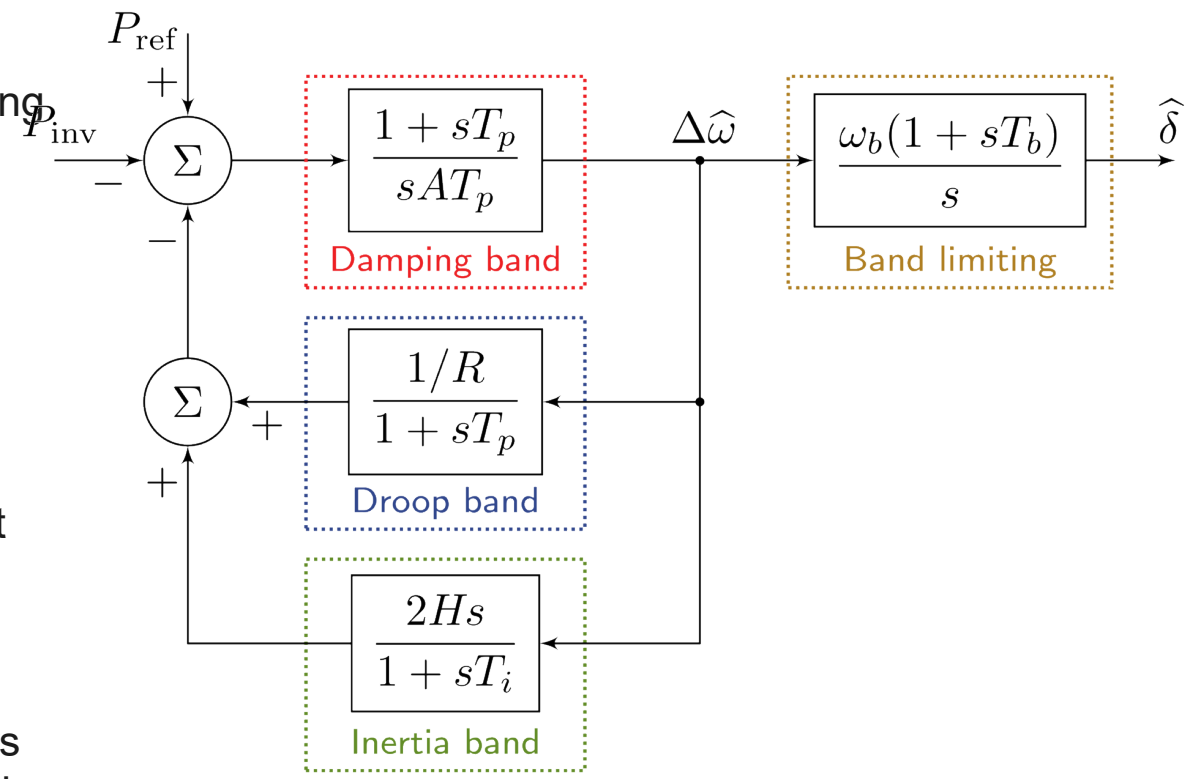

Fig. 1. Proposed active power-frequency control.

# ENERGY STORAGE CONTROL – GENERALIZED SYNCHRONOUS MACHINE ARCHITECTURE



- **What progress has been made?**

- We developed a generalized synchronous machine architecture that clearly delineates active power control functions, allowing storage owners to select options that complement revenue-generating services, such as energy arbitrage.
- We implemented this control strategy in a new open-source software release, *the Power and Energy Storage Systems Toolbox (PSTess)*, v1.1, which will make advanced control capabilities widely available.

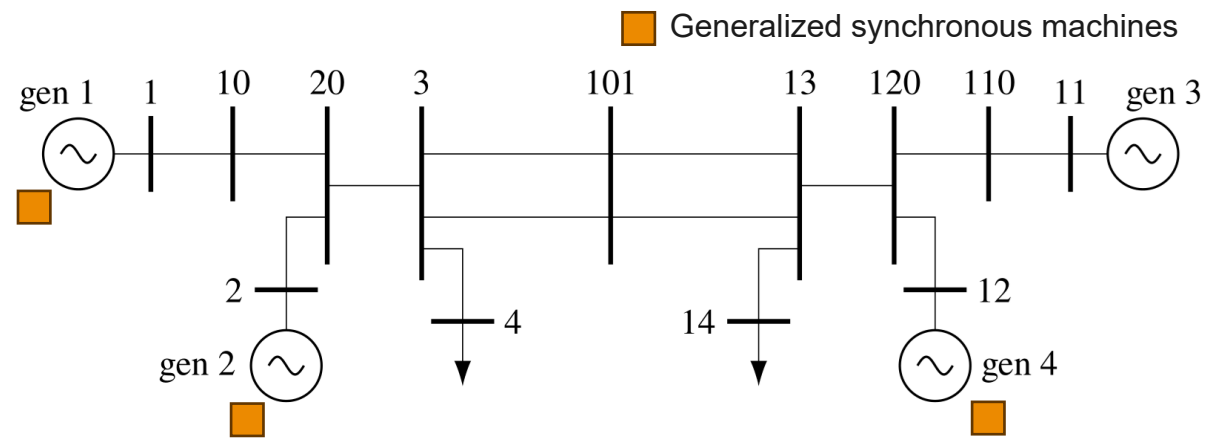

Fig. 2. Kundur 2-area system with generalized synchronous machine controlled battery energy storage systems.

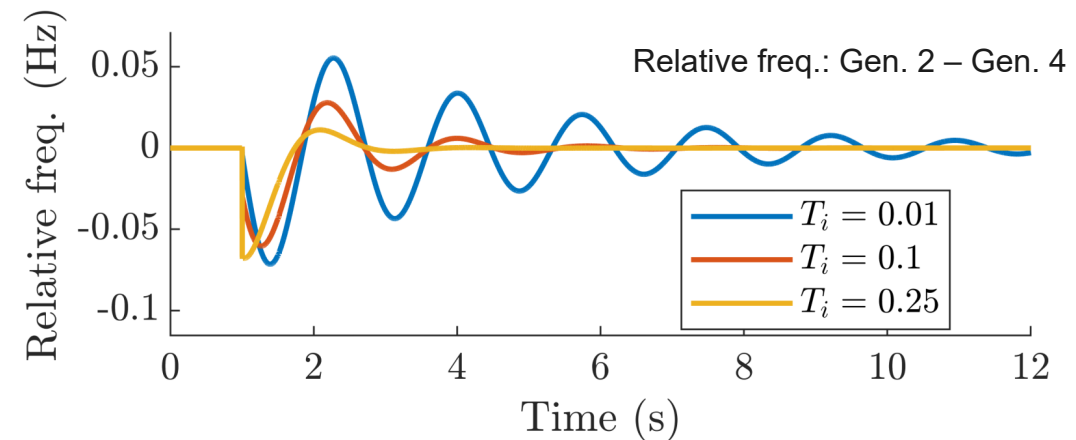

Fig. 3. Improvement in the system response to a trip of Gen. 3 as the inertia-band parameter  $T_i$  is varied.

# ENERGY STORAGE CONTROL – GENERALIZED SYNCHRONOUS MACHINE ARCHITECTURE



- We developed strategies for identifying stable tuning parameters for energy storage controls, which are critical to ensuring stable and reliable performance when integrated into a power grid.
- Our approach also considers additional conditions to achieve specific performance criteria, such as damping ratio—the rate at which oscillations decay following a disturbance.

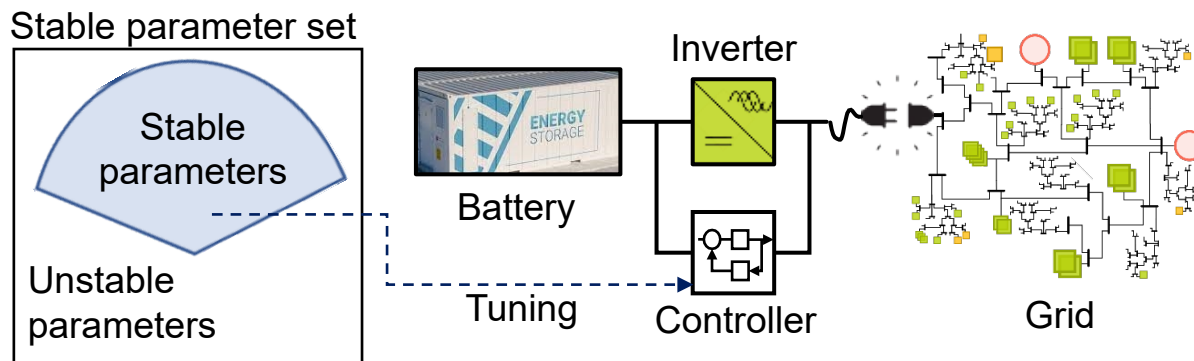

Fig. 4. Illustration of control tuning via stable parameter set.

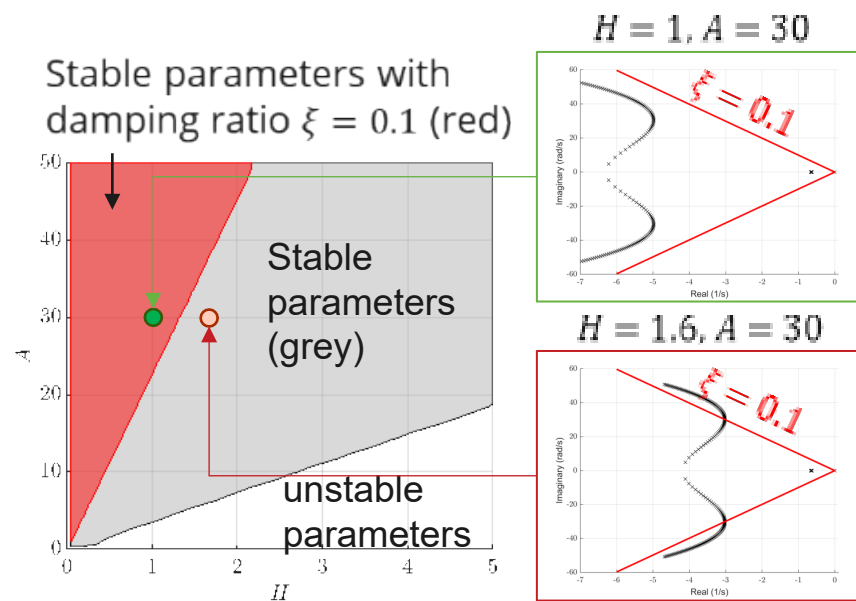

Fig. 5. Results on estimating stable parameter sets enforcing damping ratio performance criteria.

## • What are the next steps?

- Develop robust control tuning strategies to address varying operating conditions and account for the impact of inter-area dynamics between various power-grid components.
- Publish a high-quality journal paper and technical advance to showcase the benefits of the generalized synchronous machine architecture and support the development of intellectual property.



# SOFTWARE DEVELOPMENT

# GLOBAL ENERGY STORAGE DATABASE



**Objective:** Provides research-grade information on existing grid-connected energy storage projects

**Team:** : Andres S. Lopez Ramirez, Ujjwol Tamrakar, Will McNamara, Tu A. Nguyen

## • Why is the work needed?

- Publicly accessible database on energy storage projects can help in research and deployment by providing valuable information and characteristic data to different stakeholders
- ***Need automated validation and identification mechanisms*** for new storage projects
  - Keep the database updated and accurate

## • What we do?

- Maintain an online database for grid-connected energy storage projects around the globe
- Develop backend mechanism using AI (Large Language Models)
  - Supplement missing data from existing entries in the database
  - Automate identification and validation of new data entries

DOE Global Energy Storage Database Home Projects Policies Statistics About

### Search Projects

Search for any data here, or use advanced fields below:

Search for Project within the Global Map

Select Projects to Download

Export Selected Projects to JSON Export Selected Projects to CSV

Search for Projects

	Name	Location	Technology	Rated Power (kW)	Duration (hrs)	Status
<input type="checkbox"/>	Ponale (Riva del Garda Ledro) Hydroelectric Power Station	Italy	Electro-mechanical energy storage	80000		-
<input type="checkbox"/>	Urdiceto Hydroelectric Power Station	Spain	Electro-mechanical energy storage	7200		-
<input type="checkbox"/>	Rocky River Pumped Storage Plant	United States	Electro-mechanical energy storage	29000		-

QR Code:

DOE Global Energy Storage Database  
<https://gesdb.sandia.gov/>

# GLOBAL ENERGY STORAGE DATABASE



## • What is the progress?

- Web scraping framework developed to automate data entries to GESDB
- Uses Large Language Models (LLMs) for extraction data adhering to GESDB data schemas
- Several validation procedure inbuilt to ensure data accuracy

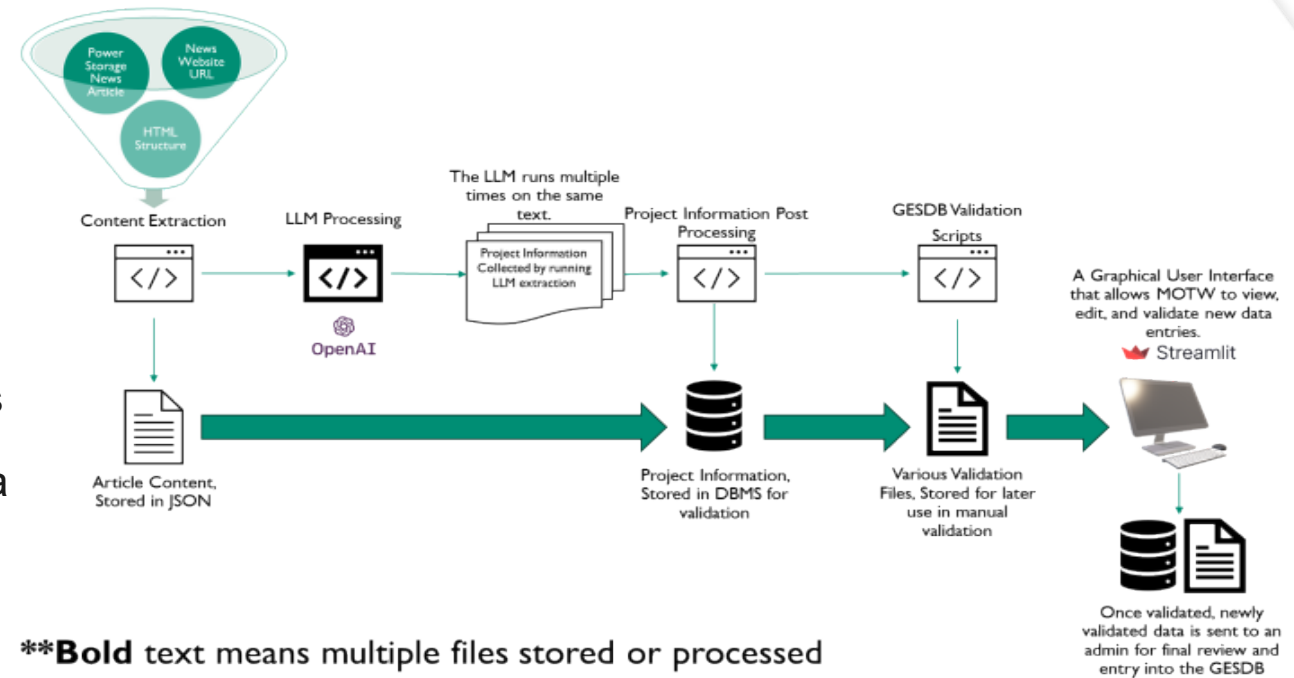

## Web scraping Framework for GESDB

## • What are the next steps?

- Continue periodic updates for known sources (EIA860, Data submitted directly from users, ... )
- Develop LLM-based method to automatically fill missing data from current GESDB entries
- Periodic maintenance of website

# IMPROVEMENTS TO THE QUEST PLATFORM



**Objective:** Improve QuEST's usability and user experience by simplifying installation, reducing package size, and resolving platform-specific issues.

Team: Tu Nguyen, Yung-Jai Pomeroy

- **Why is the work needed?**

- QuEST was difficult to install and run, especially on macOS and systems without python or developer tools installed.
- The package included legacy components that increased its size and made it more difficult to maintain.

- **What we do?**

- QuEST is installable and launchable with a single command via PyPI (pip install quest-snl).
- Platform-specific executables and launch scripts allow users to run QuEST with minimal setup.
- The package and repo are streamlined to support a modular, open platform for energy analytics tools.

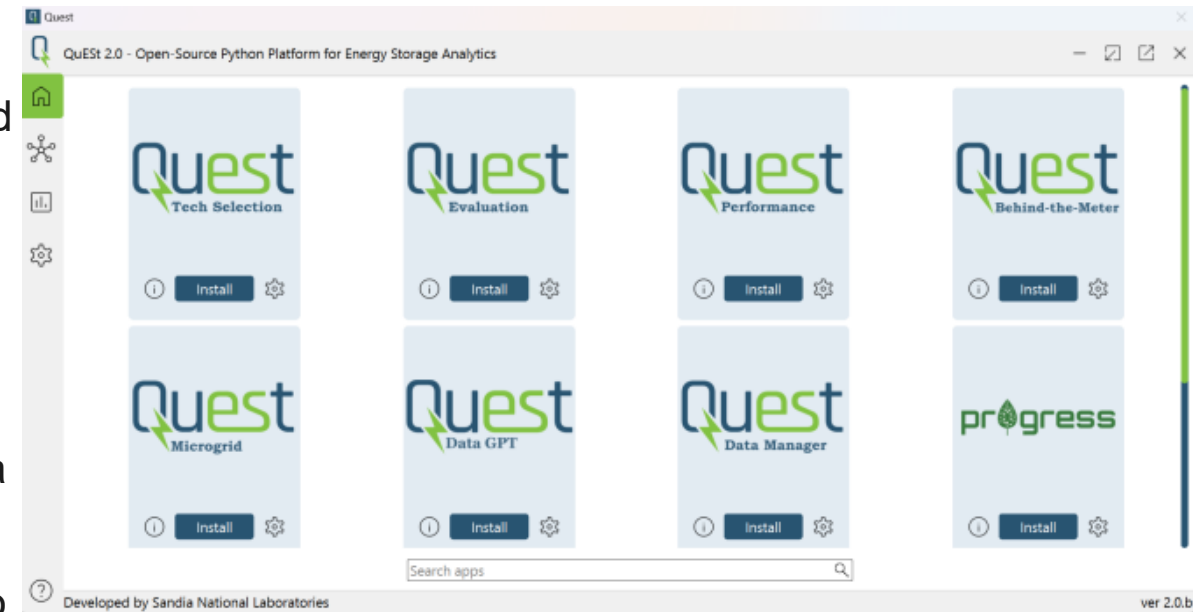

Fig. 1: QuEST GUI homepage for installing and launching analytics tools.

# IMPROVEMENTS TO THE QUEST PLATFORM



- **What is the progress?**

- QuEST is now available on PyPI and can be launched with a single command.
- Legacy components were relocated to another branch on the repository, reducing package size and improving performance.
- Git dependencies are handled at runtime with user permission, keeping the QuEST PyPI compliant.
- Platform specific executables and launch scripts are tested and working on Windows and macOS.
- Setup instructions are documented and verified for both Windows and macOS.

- **What are the next steps?**

- Add a new application to QuEST: ES4G (Energy Storage for Generation).
- Continue to grow QuEST by integrating more analytics tools.
- Improve the user experience with clearer onboarding, simplified workflows, and more intuitive tools for new users.

quest-snl 2.0.0rc4 ✓ Latest version

Released: Jul 1, 2025

```
pip install quest-snl
```

Sandia National Laboratories Energy Storage Application Platform Manage project

Navigation

- Project description
- Release history
- Download files

Project description

QuEST logo

**QuEST 2.0.b: Open-source Platform for Energy Storage Analytics**

Current release version: 2.0

Release date: March, 2024 pypi v2.0.0rc4 downloads 170/month license BSD-3-Clause

Verified details ✓

Fig. 2: QuEST is now available on PYPI for one-command installation.

# ACKNOWLEDGMENT



This material is based upon work supported by the U.S. Department of Energy, Office of Electricity (OE), Energy Storage Division.



Sandia  
National  
Laboratories



U.S. DEPARTMENT OF  
**ENERGY**

Contact: Tu Nguyen – [tunguy@sandia.gov](mailto:tunguy@sandia.gov)