

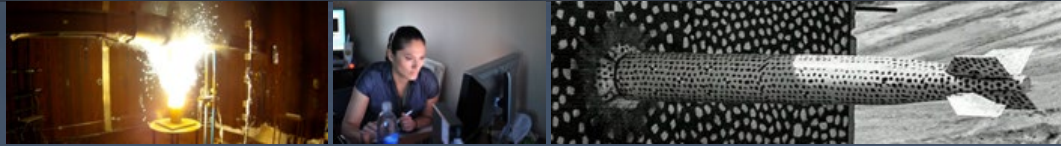

Sandia
National
Laboratories

IEEE Std 1547.9-2022

A new standard to help streamline energy storage interconnection with distribution



July 08, 2022

Michael Ropp, Ph.D., P.E.

SAND2022-9155 O



Sandia National Laboratories is a multimission laboratory managed and operated by National Technology & Engineering Solutions of Sandia, LLC, a wholly owned subsidiary of Honeywell International Inc., for the U.S. Department of Energy's National Nuclear Security Administration under contract DE-NA0003525.

The point of interconnection standards

What do interconnection standards do?

- They provide uniformity of requirements between jurisdictions.
- They provide peer-vetted, consensus-driven minimum technical requirements for interconnection.
 - Power
 - Communications
- They provide an important reference for policy makers.

IEEE Standards for Energy Storage Interconnections

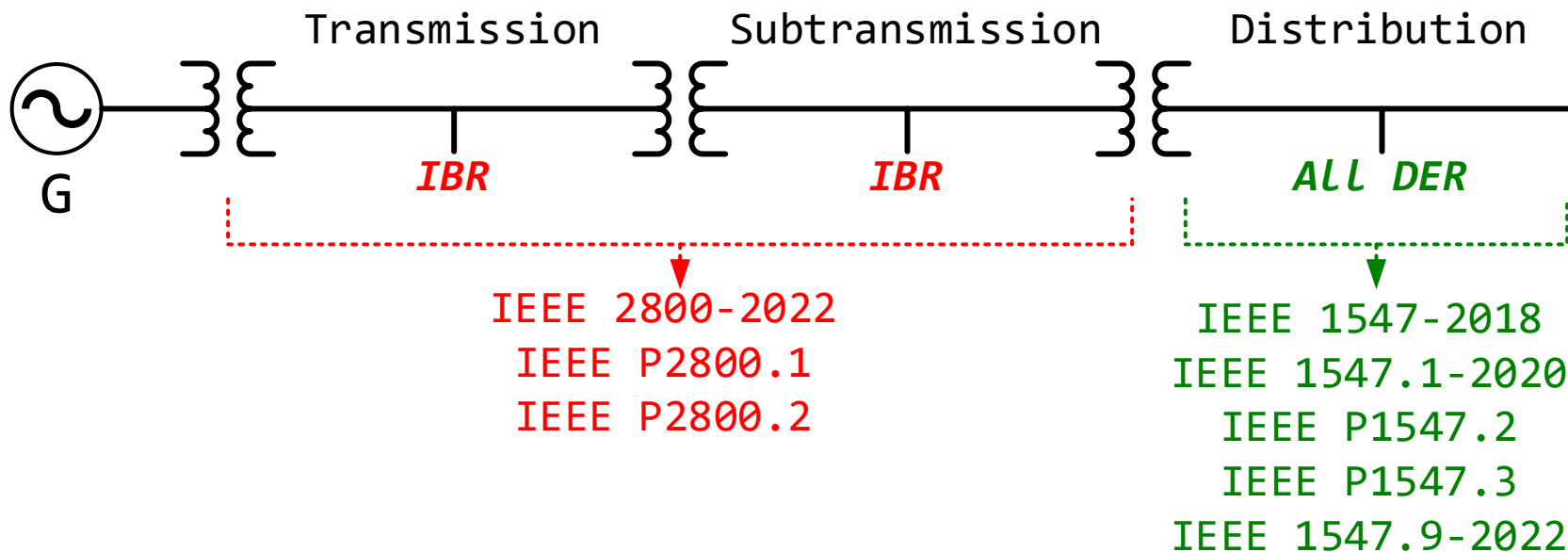

Streamlining
interconnection

Fostering innovation
and change

The IEEE 1547 family of standards

Standard number	Standard title	Status
IEEE 1547-2018™	IEEE Standard for Interconnection and Interoperability of Distributed Energy Resources with Associated Electric Power Systems Interfaces	Active
IEEE 1547.1-2020™	IEEE Standard Conformance Test Procedures for Equipment Interconnecting Distributed Energy Resources with Electric Power Systems and Associated Interfaces	Active
IEEE 1547.2-2008™	Application Guide for IEEE Std 1547	New version in balloting
IEEE 1547.3-2007™	IEEE Guide for Monitoring, Information Exchange, and Control of Distributed Resources Interconnected with Electric Power Systems	New version in balloting
IEEE 1547.4-2011™	IEEE Guide for Design, Operation, and Integration of Distributed Resource Island Systems with Electric Power Systems	Active—will need revision soon
IEEE P1547.5	Draft Technical Guidelines for Interconnection of Electric Power Sources Greater than 10 MVA To The Power Transmission Grid	Never approved; replaced by IEEE P2800
IEEE 1547.6-2011™	IEEE Recommended Practice for Interconnecting Distributed Resources with Electric Power Systems Distribution Secondary Networks	Active—will need revision soon
IEEE 1547.7-2013™	IEEE Guide for Conducting Distribution Impact Studies for Distributed Resource Interconnection	Active
IEEE P1547.8	Draft Guide for the Expanded Use of IEEE Std 1547	Replaced by full revision of the base standard
IEEE 1547.9-2022	Draft Guide to Using IEEE Std 1547™ for Interconnection of Energy Storage Distributed Energy Resources with Electric Power Systems	Approved June 2022!

Scope of IEEE 1547

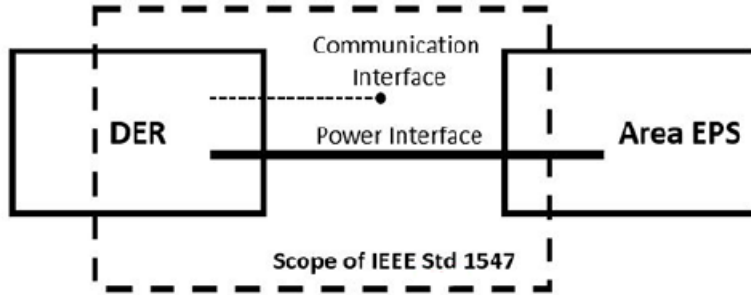

Figure 1 —Scope of this standard

1547-2018 covers the power and communications interfaces between the DER and the Area EPS (distribution system). It sets limits on what the DER can do to the Area EPS, and how the DER should “talk to” the Area EPS.

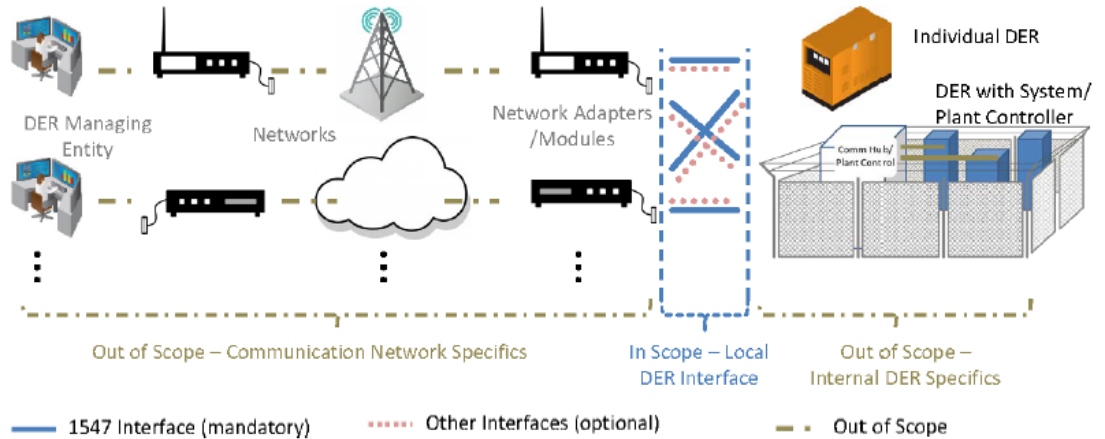

Figure 4 —Control protocol in/out of scope mapping

Why does 1547.9 exist?

- ❑ During the drafting of IEEE Std 1547-2018, there was an effort to create a subclause dealing with interconnection aspects that were specific to energy storage.
- ❑ Ultimately that subclause was not included in the final document, but IEEE SA and 1547 leadership agreed that the conversation pointed to the need for an ES-specific Application Guide. 1547.9-2022 is that Guide.
- ❑ “Why not include this as a subclause in IEEE Std 1547.2?”
 - ❑ A key reason was that it was desired that these energy storage-specific aspects draw from the energy storage community as much as from the power systems community. Thus, ***1547.9 was co-sponsored by SCC21 and the ESSB committee, and had a co-chair from each.***
 - ❑ For convenience, it was decided to split out into a separate document the guidance on application of 1547-2018 that is specific to ES DERs.

What's in 1547.9?

1547.9 focuses on applying 1547 to energy storage. Examples:

- ES-specific terminology (e.g., “operational SoC” and “operational capacity”)
- Black Start
- Clarifying volt-var support modes
- Fast Frequency Response
- Voltage and Frequency Ride-through Exemptions
- ES DERs in Secondary Networks
- ES Specific Changes in Interoperability requirements
- ES DER’s specific testing requirements
- Safety
- V2G

What's in 1547.9?

Scope clarification

Any energy storage DER that is “capable of active power export” is in-scope. What does that mean?

capable of exporting active power = any ES DER that is capable of serving load simultaneously with the Area EPS.

Examples of systems and whether they are in-scope:

UPS?	PV + ES?	V1G?	V2G?
No	Yes	No	Yes

When will 1547.9 be “official”?

It is now!! 1547.9-2022 is available in IEEExplore.

Dates	Activities	Status
February 28, 2019	P1547.9 WG meeting – WG initiated	Done
June 6, 2019	P1547.9 WG Meeting – Draft 1 initiated	Done
Oct 31- Nov 1, 2019	P1547.9 WG Meeting (online) Draft Content Review	Done
February 24-25, 2020	P1547.9 WG Meeting – WG input on D1.0	Done
June 8-12, 2020	P1547.9 WG Meeting – WG input on D2.0	Done
Oct 5-6, 2020	P1547.9 WG Meeting – WG Input on D3.0	Done
Feb. 22, 2021, virtual	P1547.9 WG Meeting –WG Input on D4.0	Done
March 17, 2021	WG comments due to officers	Done
May 17 (?), 2021	Draft 5.0 published for WG review	Done
June 07-08, 2021	P1547.9 WG Meeting – <u>WG Review Ballot Draft</u>	Done
Q2 2021	P1547.9 Ballot draft approved by WG	Done
Q3 2021	P1547.9 To IEEE-SA for ballot	Done
Q3 2022	IEEE Std 1547.9-2022 Published	Done

Thank you!

Please feel free to email me with questions:

meropp@sandia.gov

**Special thanks to Dr. Imre Gyuk, DOE – Office of
Electricity, Energy Storage Program.**

What's in 1547.9?

- ❑ The clause structure of 1547.9 is identical to that of IEEE Std 1547-2018, down to the second subclause (i.e., down to Clause #.#.#). Once you get below that (Clause #.#.#.#) 1547.9 may track differently than the base standard.
- ❑ Exceptions:
 - ❑ 1547.9 has a Clause 12 on safety. 1547-2018 doesn't have a clause 12.
 - ❑ 1547.9 clause 11 is partly about 1547-2018 but mostly about 1547.1-2020.
- ❑ Direct references to 1547 clauses are shown in blue and marked with [1547], like this: “**Clause #.#.# [1547]**”.
- ❑ In some subclauses, you will see this text: “***Subclause #.#.# [1547] applies to ES DER without further guidance.***”

What's in 1547.9?

What IS “operational state of charge”?

- **operational state of charge**: the usable energy stored as a proportion of the operational capacity, expressed as a percentage.
- **operational capacity**: the estimated energy that an energy storage system can provide on discharge, subject to operational constraints. Examples of factors influencing operational capacity include rated energy, state of health, discharge rate, temperature, and usable state-of-charge range.

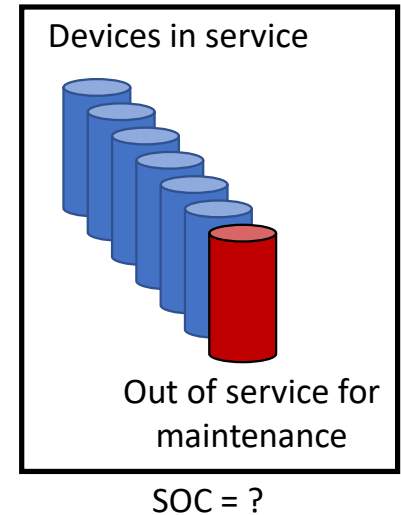
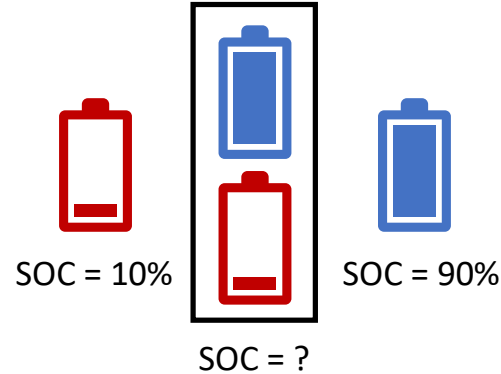

What's in 1547.9?

Operational models

Operational state of charge and operational capacity aren't sufficient for automated control or state forecasting. For that, an operational model is needed, and 1547.9 discusses them. The figure at the right demonstrates some of what an operational model can tell you.

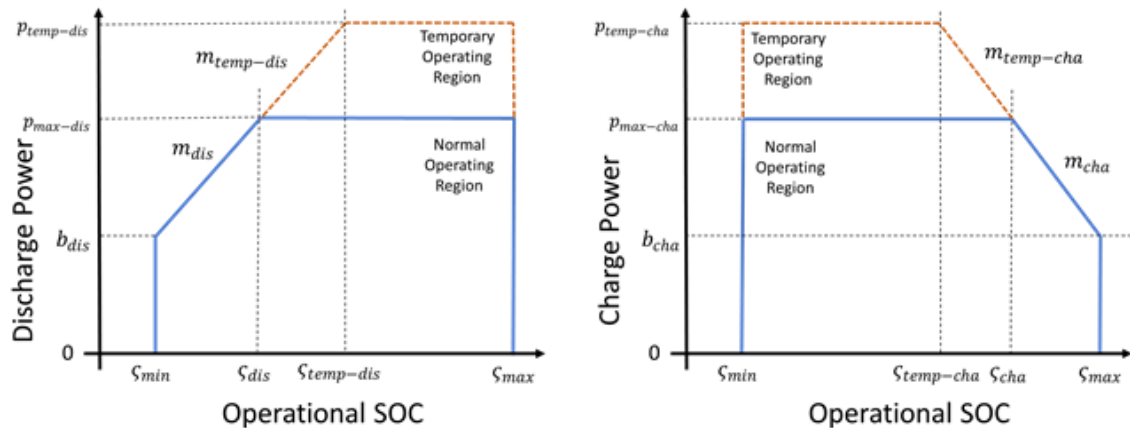

Figure 3—Discharge power (left) and charge power (right) operating regions defined by the operational model constraints

What's in 1547.9?

Participation in black start/system restoration

- ❑ An ES DER with isochronous control capability might energize an intentional (planned) island.
- ❑ If that ES DER is allowed to temporarily energize some part of the Area EPS outside of the planned island, then it may assist in system restoration after an outage.
- ❑ However, 1547-2018 only discusses reconnection of an intentional island system to an Area EPS *that is already energized*. There is no provision for connecting a de-energized part of an Area EPS to an energized intentional island.
- ❑ 1547.9 suggests that this kind of assistance with restoration can be allowed, in coordination with the Area EPS operator. Synchronization conditions, adjustments to some parameters, and ensuring ES DER operator awareness of the responsibilities concomitant with participation in system restoration are all discussed.

What's in 1547.9?

Clarifying volt-var support modes while charging

It is recommended that ES DER comply with Normal Operating Performance Category B. In Clause 5, 1547.9 clarifies how these extend into the charging region.

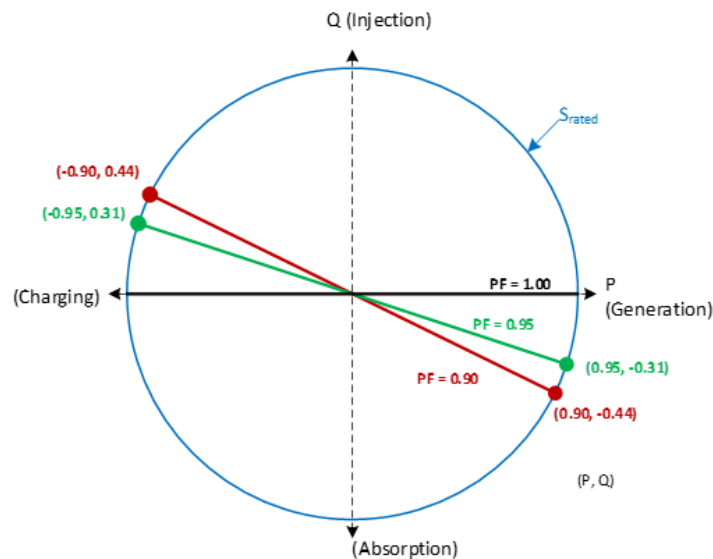
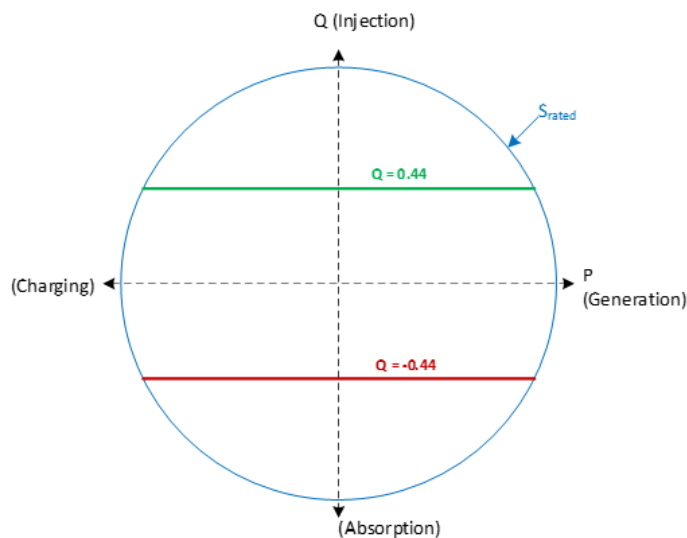

What's in 1547.9?

Fast Frequency Response (FFR)

The graphic at right illustrates various levels/time scales of frequency response to an underfrequency event. ES DERs can also respond to overfrequency events by charging/importing active power.

(This figure is from IEEE 2800-2022.)

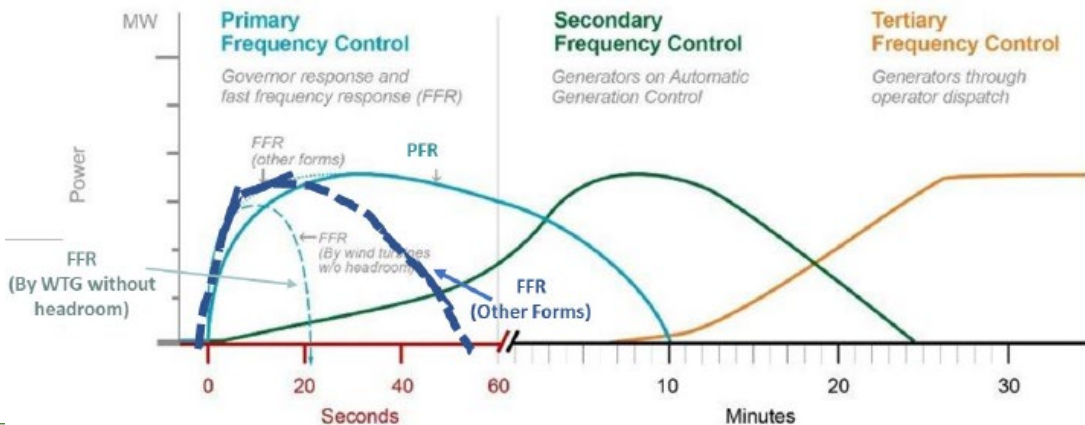
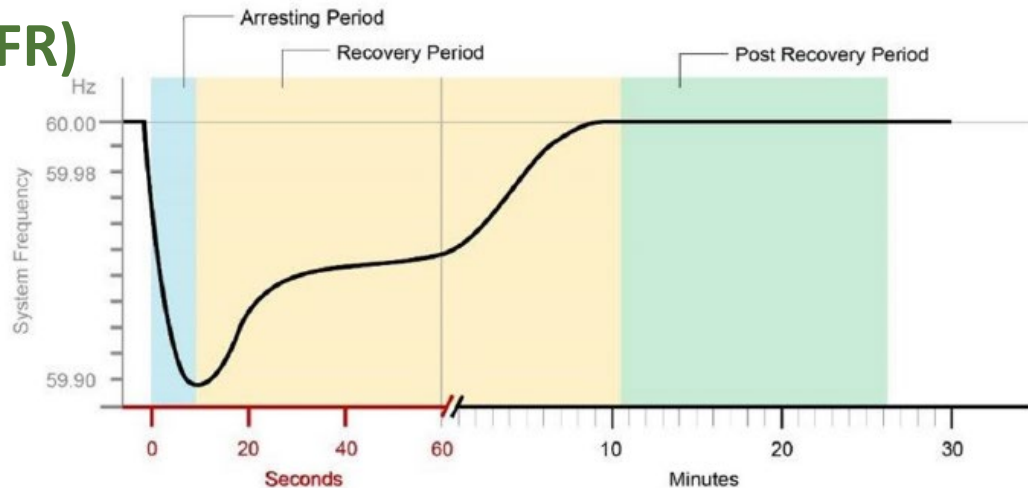

What's in 1547.9?

Fast Frequency Response (FFR)

- 1547-2018 permits, but does not require or further describe, fast frequency response (FFR). FFR comes in different forms such as synthetic inertial response (power $\propto df/dt$). It is likely that FFR will be deployed in many ES DERs.
- 1547.9 discusses inertial response and its deployment in ES DERs. *(Note: IEEE 2800-2022 does require FFR capability and goes into detail on FFRs for transmission-connected ESSs.)*

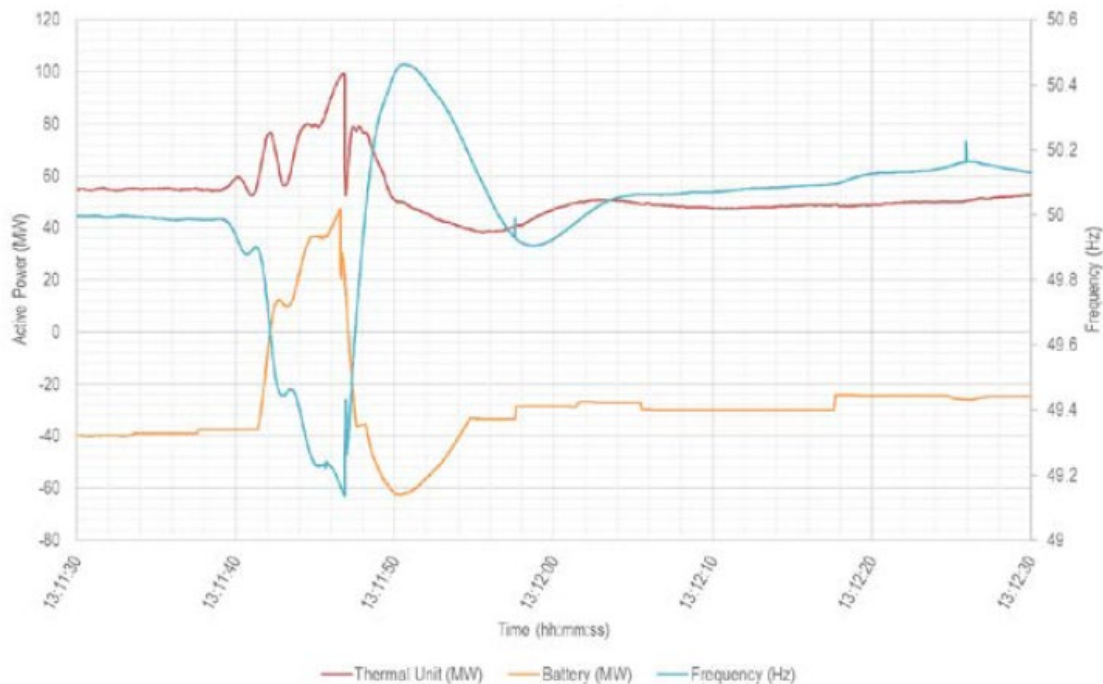

What's in 1547.9?

The “take your load with you” clause

- In 1547-2018 clauses 6.4.2 and 6.5.2, there is an exemption from voltage and frequency ride-through requirements for DERs that “take their load with them”. This applies if the Local EPS:
 - Is controlled so that export is never greater than 10% of the aggregate of all DERs in the Local EPS; *or*
 - An amount of load equivalent to at least 90% of the pre-disturbance Local EPS output is shed simultaneously.
- These put limits on *export*, but not *import*. **That is to be read as-is.**
- If ES DERs are engaged in non-active-export services, such as var support, then the ES DER and Area EPS operators should work out when and how these exceptions might apply.

What's in 1547.9?

ES DERs in secondary networks

Key challenge: DERs on secondary networks aren't allowed to discharge in such a way that reverse power flow through network units might occur.

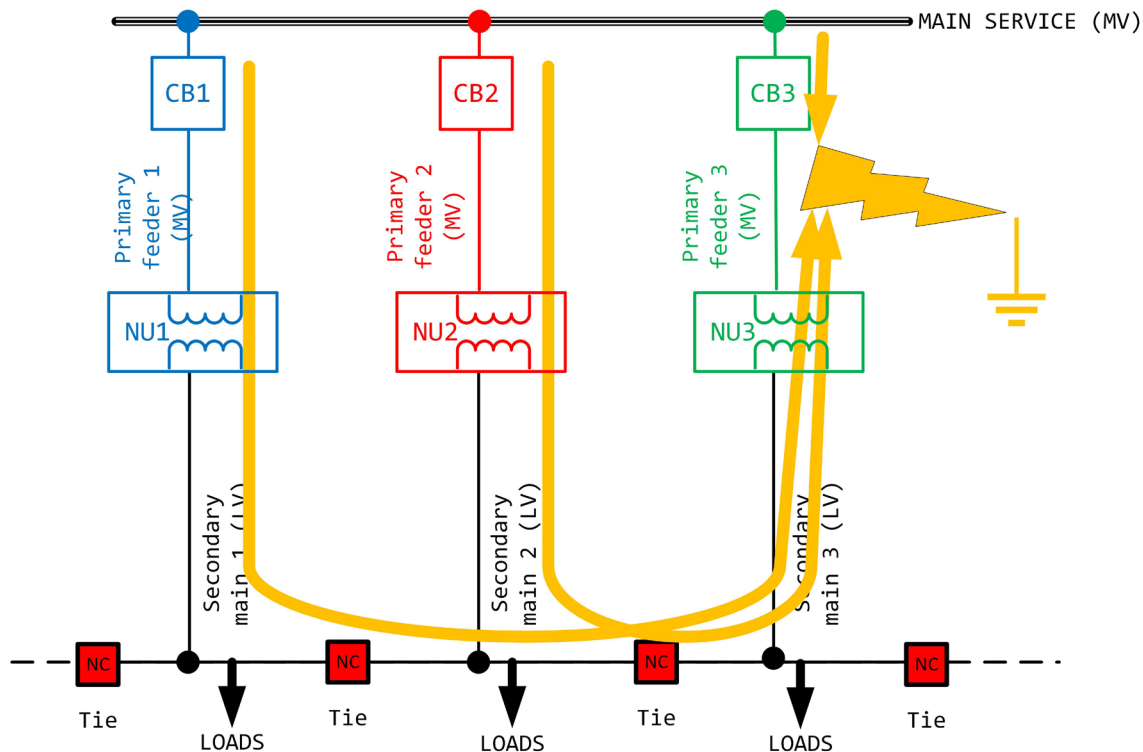

What's in 1547.9?

ES DERs in secondary networks

ES DER may be used to absorb the output of other DERs in the secondary network to allow higher deployment levels without reverse power flow. However, careful coordination is critical.

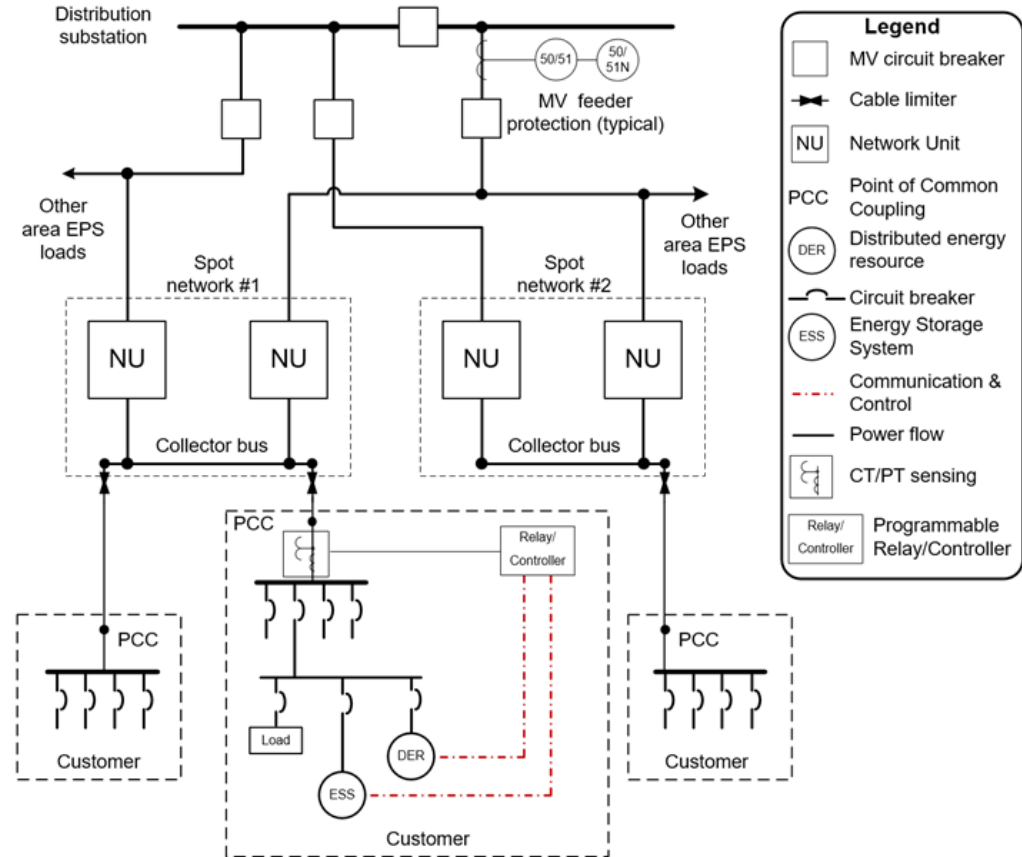

What's in 1547.9?

Interoperability, information exchange, information models and protocols

Clause 10 of 1547.9 discusses energy storage-specific changes in the interoperability requirements laid down in the base standard. *Most* of the examples are cases of ES-specific parameters that need to be added to the reporting requirements.

One example is shown at right (ESS-specific additions to Table 29 in 1547-2018).

Table 29—Monitoring information [1547]

In Table 29 [1547], the following rows should be added:

Parameter	Description
State of charge	
Temperature ^a	Temperature in degrees Celsius

^a This temperature can be the overall temperature of the ES DER unit or, for large installations, the temperatures of individual cells and/or other units.

In Table 29 [1547], the following rows should be added if the ES DER has such parameters:

Parameter	Description
Smoke Detection	Smoke has been detected indicating fire
Flame Detection	Flame has been detected indicating fire
Off-Gas Detection	Hydrogen has been detected
Fire Protection System Detection	The fire protection system has activated

In Table 29 [1547], for ES DER the following rows should be changed as shown (**emphasis** added to identify the change):

Parameter	Description
Operational State	Operational state of the DER. The operational state should represent the current state of the DER. The minimum supported states are on and off, but additional states may also be supported. Include charging and discharging as operational states of the DER.

What's in 1547.9?

ES DER-specific testing requirements

In 1547-2018 clause 11 and 1547.1-2020, there are a few places where the application to the charging mode wasn't 100% clear. 1547.9 seeks to clarify those.

Example: at the right is the Category III LVRT test signal specified in 1547.1-2020. This test is to be conducted at two output power levels, one above 90% and one between 25% and 50%.

1547.9 recommends that for ES DER these tests be conducted at four power levels: >90% exporting, > 90% importing, and 25-50% exporting and 25-50% importing.

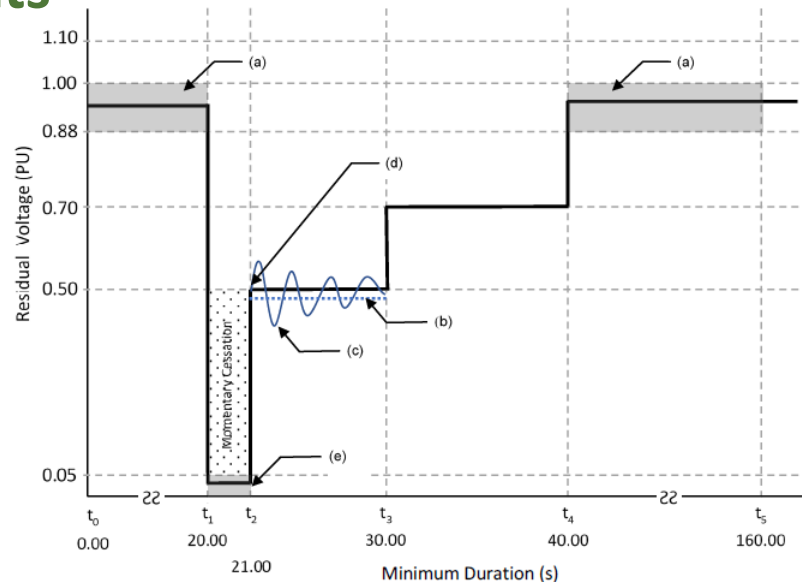

NOTES—

- (a) Any voltage between 1.00 p.u. and 0.88 p.u. is permitted.
- (b) Average of the rms voltage over duration of excursion.
- (c) Example of positively damped voltage oscillations allowed during testing.
- (d) DER shall restore output within 0.400 seconds following momentary cessation, i.e., following time t_2 .
- (e) Any voltage less than 0.05 p.u. is permitted.

What's in 1547.9?

Safety

- This clause has no direct parallel in 1547-2018.
- Safety is a crucial topic when dealing with ES DERs. Thus, although *safety considerations are outside of the scope of 1547*, the 1547.9 working group thought it of value to collect examples of existing safety codes and standards and to provide some examples of safety-related topics and subsystems. Clause 12 contains this information.

What's in 1547.9?

V2G

- SAE International produces consensus standards governing vehicle systems and components.
- IEEE produces consensus standards governing interconnection with power grids.
- Here, the two jurisdictions overlap.

In scope of 1547.9?

Charger location	V1G	V2G
Onboard	No	Yes, via SAE J3072
Offboard	No	Yes

Impact of Revising IEEE 1547-2003 on ES Applications

Category	Storage "End Use"
ISO/Market	<ul style="list-style-type: none"> • Frequency regulation • Spin/non-spin/replacement reserves • Ramp • Black start • Real time energy balancing • Energy price arbitrage • Resource adequacy
VER Generation	<ul style="list-style-type: none"> • Intermittent resource integration: wind (ramp/voltage support) • Intermittent resource integration: photovoltaic (time shift, voltage sag, rapid demand support) • Supply firming
Transmission/ Distribution	<ul style="list-style-type: none"> • Peak shaving: off-to-on peak energy shifting (operational) • Transmission peak capacity support (upgrade deferral) • Transmission operation (short duration performance, inertia, system reliability) • Transmission congestion relief • Distribution peak capacity support (upgrade deferral) • Distribution operation (Voltage Support/VAR Support) • Outage mitigation: micro-grid
Customer 7	<ul style="list-style-type: none"> • Time-of-use /demand charge bill management (load shift) • Power quality • Peak shaving (demand response), Back-up power

1547-2003 vs. new CA 21 & 1547 Revision



<https://standards.ieee.org/standard/1547-2018.html>

<https://standards.ieee.org/project/2800.html>

<https://cmte.ieee.org/pes-essb/>

<https://www.sandia.gov/ess-ssl/>

<https://www.sandia.gov/energystoragesafety-ssl/>

<https://www.nerc.com/pa/Stand/Workshops/NERC%20101.pdf>

https://www.nerc.com/comm/PC_Reliability_Guidelines_DL/Inverter-Based_Resource_Performance_Guideline.pdf

<https://www.nerc.com/comm/PC/Pages/Inverter-Based-Resource-Performance-Task-Force.aspx>

<https://www.ferc.gov/industries-data/electric/industry-activities/nerc-standards>

https://www.ferc.gov/sites/default/files/2020-04/reliability-primer_1.pdf