

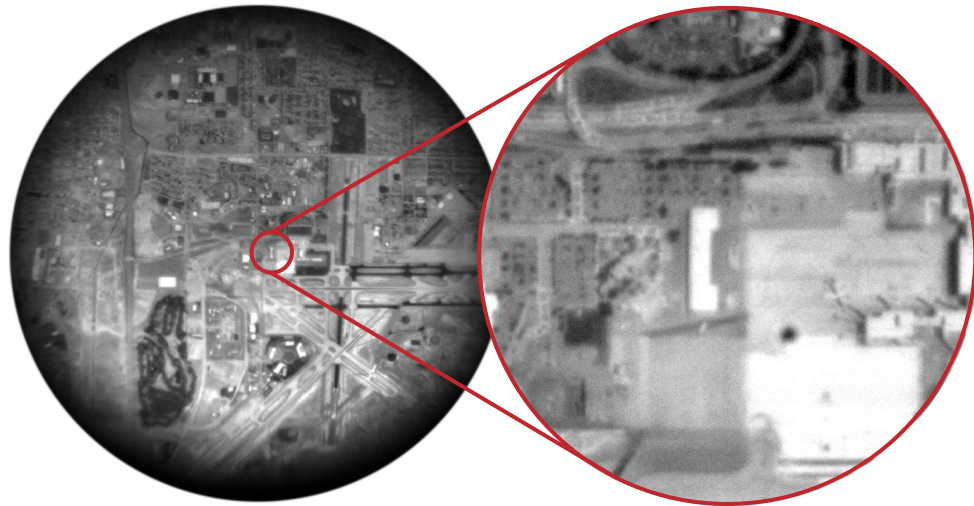

Microelectronics and Microsystems Optical Military Systems

Adaptive Optical Systems

Figure 1: 8X zoom images using adaptive polymer lens rifle scope developed jointly with Holochip, Inc., for the Army's Armament Research Development and Engineering Center. There is no longitudinal motion or additional optics flipped into the optical train, as is currently done in conventional zoom systems.



*Sandia technologies
provide innovative
imaging capabilities for
situational awareness in
the field*

For more information:

Technical Contacts:

David Wick
505-844-2517
dvwick@sandia.gov

Brett Bagwell
505-284-5639
bbagwel@sandia.gov

Science Matters Contact:

Alan Burns
505-844-9642
aburns@sandia.gov

Adaptive optical systems have been in use for over 30 years, mainly to correct atmospheric turbulence in ground-based telescopes or to improve the spatial mode and power of lasers. More recently, Sandia has led the innovation of using adaptive elements, such as deformable mirrors and spatial light modulators, to increase the resolution, magnification, field-of-view, or spectral bandwidth of imaging systems. Integration of electronically-controllable elements into a conventional lens or telescope system can increase performance or add flexibility while reducing size, weight, and power requirements. Sandia's work has supported the Defense Advanced Research Projects Agency (DARPA), the Air Force Research Laboratory (AFRL), the Office of Naval Research (ONR), and the Missile Defense Agency, and has been referenced in the development of commercially available adaptive microscopes and transmissive spatial light modulators.

An example of adaptive optical technology is shown in Figure 1, where an 8X change in magnification in a rifle scope is performed

without the need for longitudinal mechanical motion, as is done in a conventional zoom lens. Instead of moving lenses, the adaptive optical zoom uses micro-opto-electro-mechanical systems, such as adaptive polymer lenses or segmented micro-electro-mechanical mirrors, to change the magnification. This concept can also be used with Sandia-developed ultralight thin-film mirrors or carbon fiber reinforced polymer mirrors for ground and space applications that require larger apertures. A telescope is now being developed that uses these variable radius mirrors to increase situational awareness while maintaining ultra-high resolution, or to improve rendezvous and docking capability. Adaptive optical zoom is ideal for applications which require both a wide field-of-view and the ability to quickly transition to high resolution for identification.

Working closely with AFRL and the Naval Research Laboratory, Sandia has also developed foveated imaging, where bulky fisheye lenses are replaced with compact, lightweight, wide field-of-view optical systems. Foveated imaging provides a

wide field-of-view (120° or more) from an extremely compact system. Rather than adding glass lenses to increase the field-of-view, as is normally done in wide-field lenses, a 1280x1024 liquid crystal spatial light modulator (SLM) is used to correct aberrations over a small area within the wider field-of-view (Figure 2). Thus, the system maintains diffraction-limited performance over a selected area of interest, with lower resolution in the periphery, similar to the human fovea.

Foveated systems are currently being developed for small unmanned aerial vehicles, where the size and weight of conventional “fish-eye” lenses are too great. DARPA based their Bio-Optic Synthetic Systems (BOSS) program, in part, on Sandia’s technology. In the fielded system shown in Figure 2, the length of the lens was reduced from 19 cm to 7 cm and the volume of glass in the lens was reduced by a factor of ten. This system maintained high imaging quality out to 120°. Foveated zoom systems utilizing MEMS mirrors are also being developed

jointly with Lockheed Martin for acquisition, discrimination, and tracking. These reflective systems can quickly toggle between wide and narrow fields-of-view, magnifying any area of interest within the wider field. When zoomed-in, they can optically track a target without slewing the entire system. Thus, a foveated zoom system can survey a wide area, zoom-in quickly on multiple potential threats for discrimination, and track a target in near real-time.

In summary, adaptive optics has allowed Sandia researchers to transcend conventional glass optical systems and improve capability in many applications of interest to the military. In the case of optical zoom, these technologies allow a user to increase the resolution over an area-of-interest in near real-time and may eventually eliminate the need for gimbaled or multiple camera systems commonly used for acquisition and tracking.

Liquid Crystal SLM

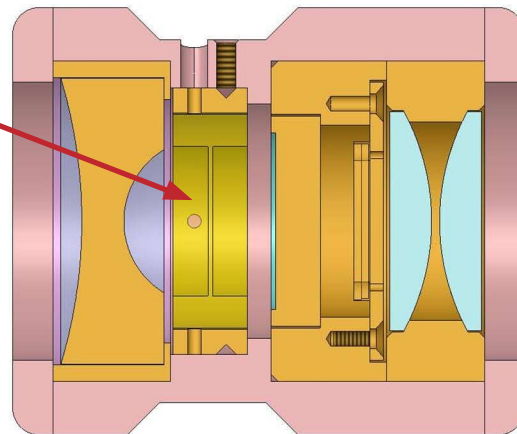

Figure 2: Foveated imaging lens developed under DARPA BOSS. The lens houses a liquid crystal spatial light modulator (developed for Sandia by Boulder Nonlinear Systems and the University of Central Florida) to dynamically correct aberrations at any point.