



Z Diagnostic Update

SAND2022-10451 C

Z Fundamental Science Workshop

8/3/2022

Michael Jones on behalf of the Z Diagnostic Team



Sandia National Laboratories is a multimission laboratory managed and operated by National Technology & Engineering Solutions of Sandia, LLC, a wholly owned subsidiary of Honeywell International Inc., for the U.S. Department of Energy's National Nuclear Security Administration under contract DE-NA0003525.

2 | Agenda



- Diagnostic Organizations and Team
- NDWG Update
- Z Machine Overview and Interface with Diagnostics
- Diagnostic Capability Overview
- Diagnostic Updates

Target diagnostics are organized into five different areas.



X-Ray Diagnostics	Fusion Diagnostics	Diagnostic Technologies	Velocimetry	Power flow
Michael Jones	Dave Ampleford	John Porter	Chris Seagle	Jen Schwarz
Power and Energy XRDs, PCDs, SiDs, Bolometers, GaAs, TEP SCORPIONZ* X-Ray Spectroscopy TIXTLs TREX CRITR TiGHER XRS3, MONSSTR X-Ray Imaging TRIXCI MLM WALLE Crystal Imaging Crystal Backlighting TIPC APE, SOPI Wolter	n Yield & Spectrum nTOFs* Activation Sample Be Probe CRS* Neutron Imaging ODIN NEMESIS* Burn History PAJARITO* GRH* ACD MCVD NBT	UXI in: - backlighting - MONSSTR - Axial Spectrometer FOA Pinhole Camera UPAC Diode Development GaAs* Faster Silicon*	VISAR PDV Pyrometry Diffraction*	SVS Line VISAR FCAPs Mini-XRDs APDs CIDZ UV Spectroscopy* SEGOI* FIZ*
* Active Development				

We have an energetic team of technologists, engineers, designers, and scientists focused on improving Z's diagnostic enterprise



- Tommy Ao
- Carlos Aragon
- Phil Atencio
- Tom Avila
- Tom Awe
- Jacob Banasek
- Caroline Blada
- Dave Bliss
- Nathan Brown
- Pat Cahall
- Gordon Chandler
- Kathy Chandler
- Tony Colombo
- Gary Cooper
- Center Section
- Chris de la Cruz
- Natasha Davis
- DAS Team
- Dan Dolan
- Greg Dunham
- Aaron Edens
- Jeff Fein
- Karin Fulford
- Paul Gard
- Jeff Georgeson
- Jeff Gluth
- Richard Hacking
- Eric Harding
- Aaron Hansen
- Ethan Howard
- Gerald Jackson
- Drew Johnson
- Mark Johnston
- Pete Jones
- Pat Knapp
- Pat Lake
- Derek Lamppa
- Guillaume Loisel
- Quinn Looker
- Mike Lowinske
- Larry Lucero
- Patricia Kalita
- Antoinette Maestas
- Mike Mangan
- Owen Mannion
- Dustin Marshall
- Andy Maurer
- Matt McCall
- John McKenney
- Jim Mignon
- Evan Misak
- Mike Montoya
- Robert Obregon
- Sheri Payne
- Lawrence Perea
- Radu Presura
- Pablo Reyes
- Brian Ritter
- Grafton Robertson
- Dan Scoglietti
- Ed Scoglietti
- Katie Seals
- Robert Speas
- Shane Speas
- Decker Spencer
- Jose Torres
- Tim Webb
- Gary Whitlow
- Ming Wu
- David Yager-Elorriaga
- Kevin Yates
- Colleagues from LLNL,
LANL, NNSS
- University partners
- I apologize for anyone I
have left off

National Diagnostics Working Group Update



- The National Diagnostics Working Group (NDWG) is an active and productive community focused on transformational diagnostics for Z, NIF, and LLE.
- Workshops have attendees from each site and university partners and are used to share ideas, identify solutions, and develop action plans.
- Los Alamos National Laboratory hosted last year's virtual National Diagnostic Working Group meeting (150 participants from 28 institutions). There were breakout sessions focused on:
 - high resolution x-ray imaging at MJ yields,
 - future improvements for neutron imaging and 3D reconstruction techniques,
 - advanced target characterization and metrology, and
 - burning plasma diagnostic needs
- The 2022 meeting is being planned for December 13th-15th at Sandia National Laboratories.
- Please contact Michael Jones or Eric Harding for further details

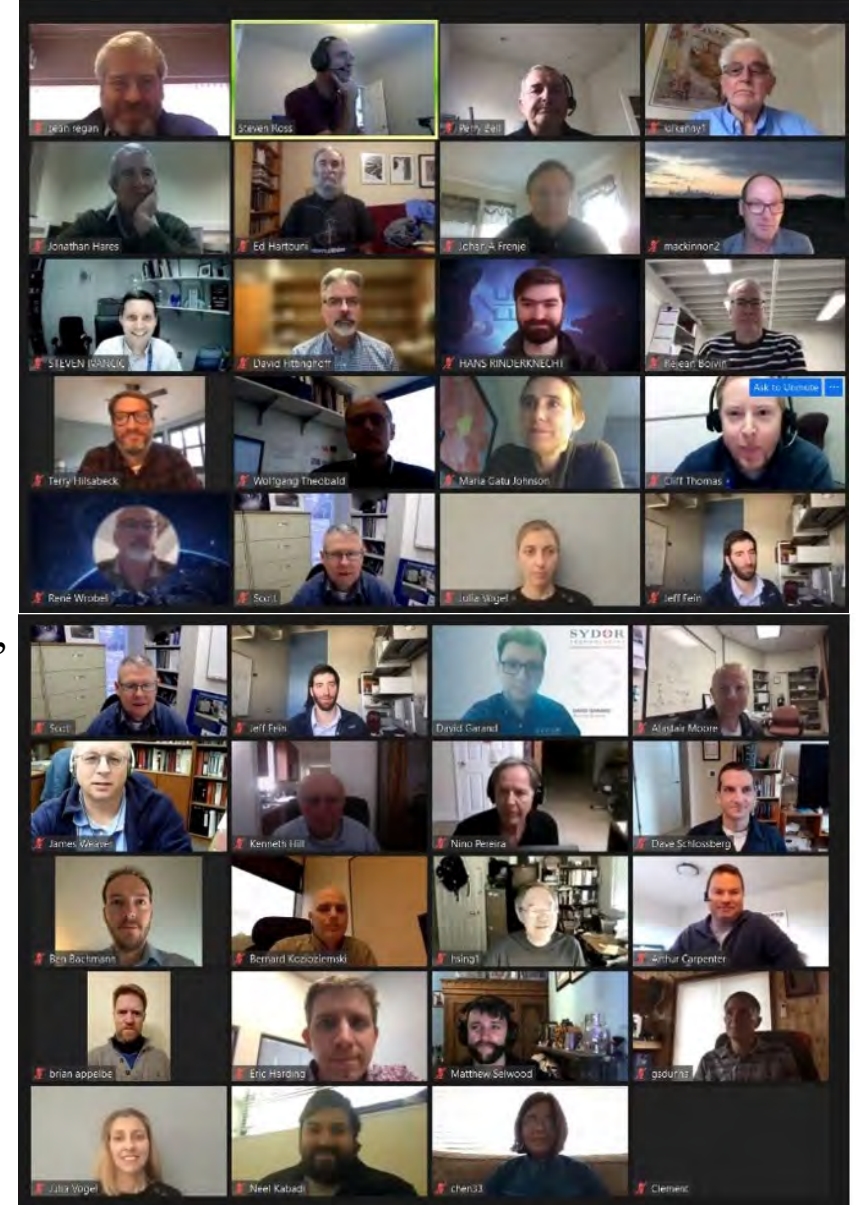

Z Compresses Energy in Space and Time to Create Extreme States of Matter that need to be diagnosed



33 m

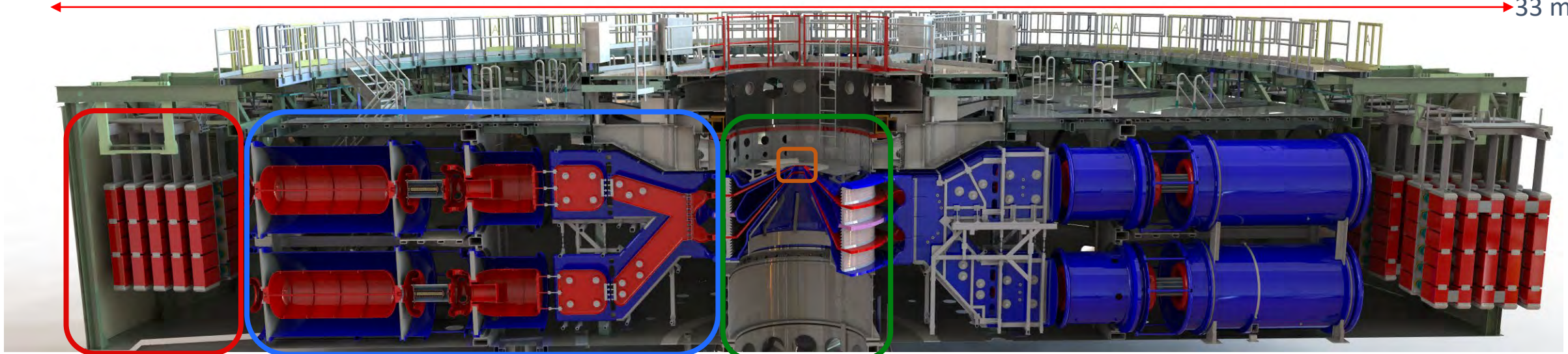

Marx Generator

Pulse Forming Storage Section

Center Section

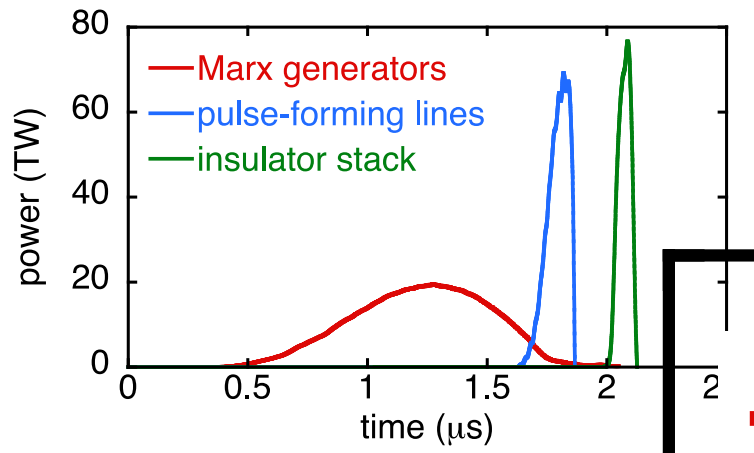

Z today couples several MJ out of 22 MJ stored to the load hardware region at the machine center.

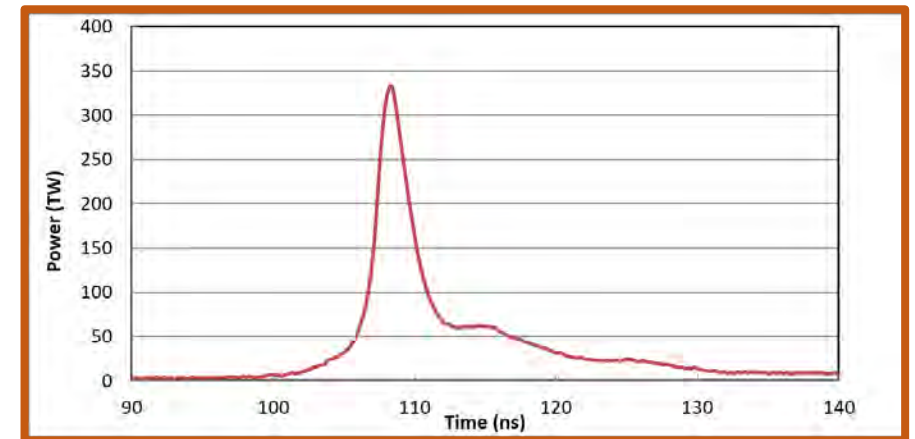

Capable of outputting >300 TW and 2MJ of x-ray output*

Diagnostic Access on Z is Limited by the Geometry of Pulsed Power Components

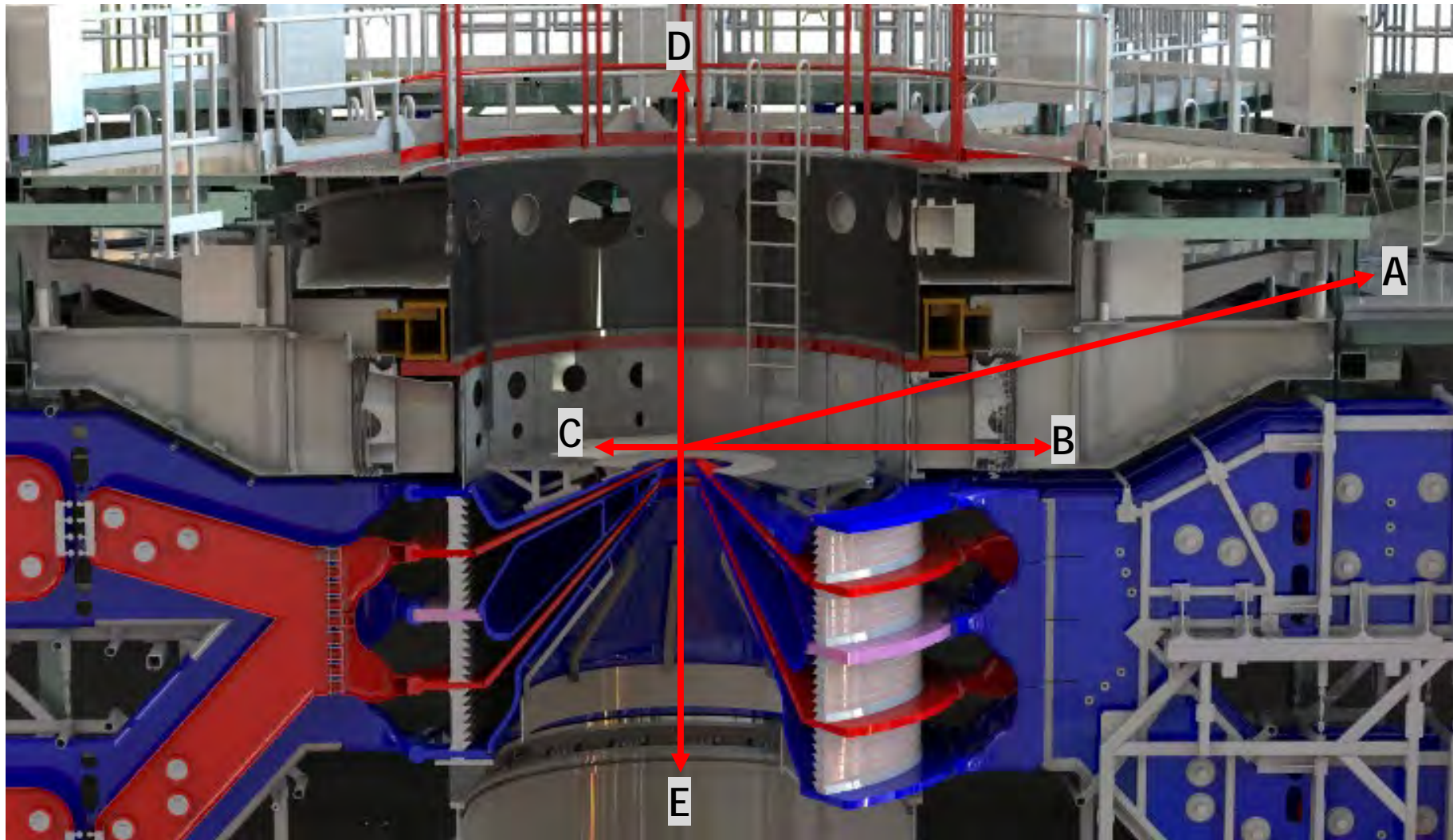

A	12° Line of Sight
B	0° Line of Sight
C	In Chamber
D	Top Axial
E	Bottom Axial

There are 18 radial Lines of Sight, spaced every 20°

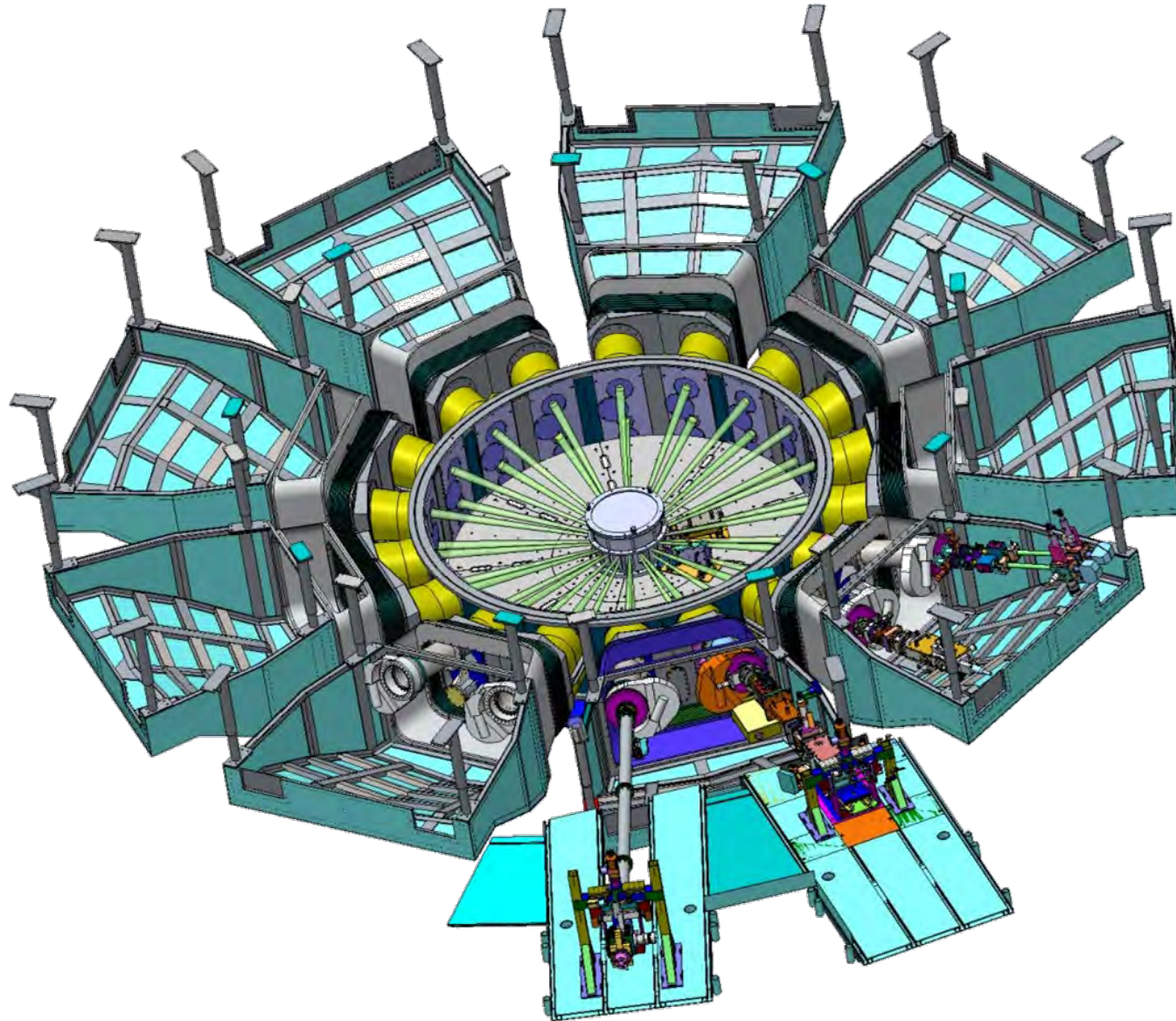

LOS	0	12
10	Gas Fill / Cryo	
30	VISAR, PDV, Containment Thermocouple	
50	TiGHER, TRIXCI	P&E
70	SVS, APD, PDI, PSB	
90	In-Chamber Diodes Will transition to SCORPIONZ	NBT
110	Line VISAR	
130		TIXTLs
150		
170	P&E	MLM
190	ACD/GRH	
210	PAJARITO	P&E
230	UXI In-Chamber	
250	MCVD	
270	nTOF	
290	Wolter	
310	Wolter Controls or 1300 in-Chamber Gas Fill	
330	TRES	
350	GTS	

- For improved sensitivity, diagnostics can be fielded as close as $\sim 10\text{cm}$ to the target. However, space is getting limited.

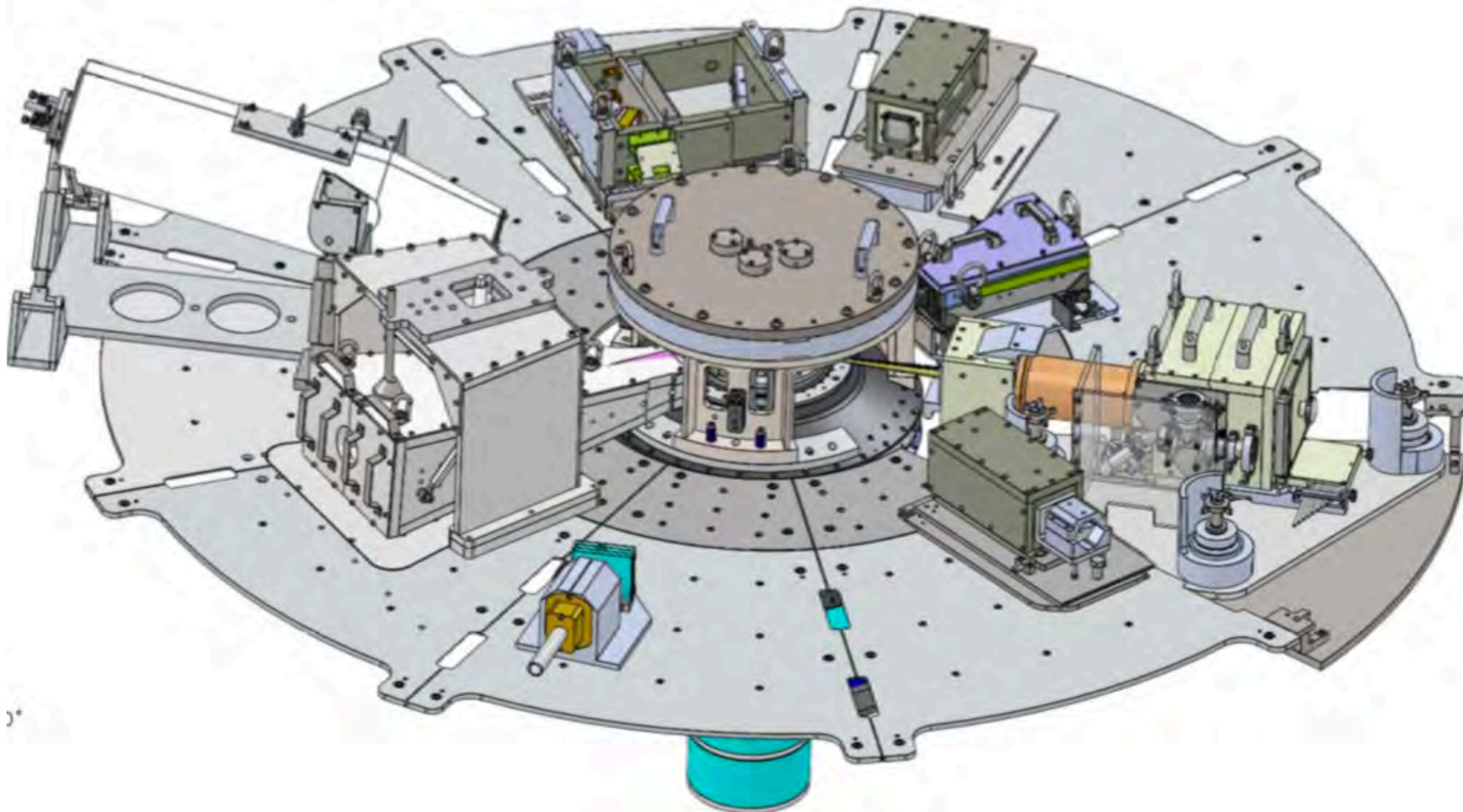

There are two axial based diagnostic platforms for use on Z



Axial Package

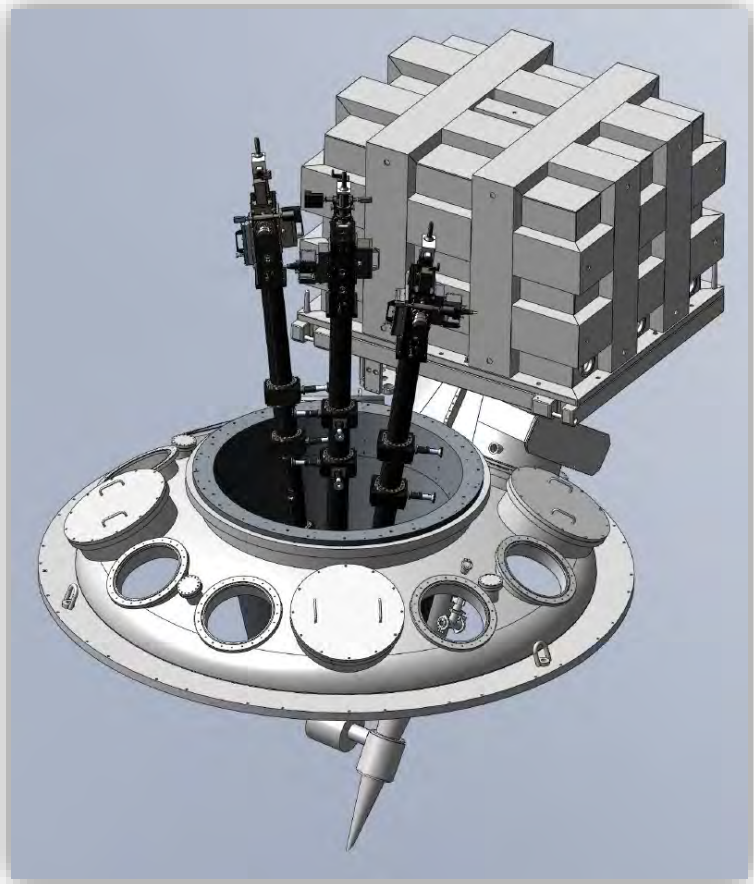

X-Ray Spectroscopy (ECP and CCP), Imaging (MIP) and x-ray diodes are available

For more information contact Greg Dunham

Vacuum FOA

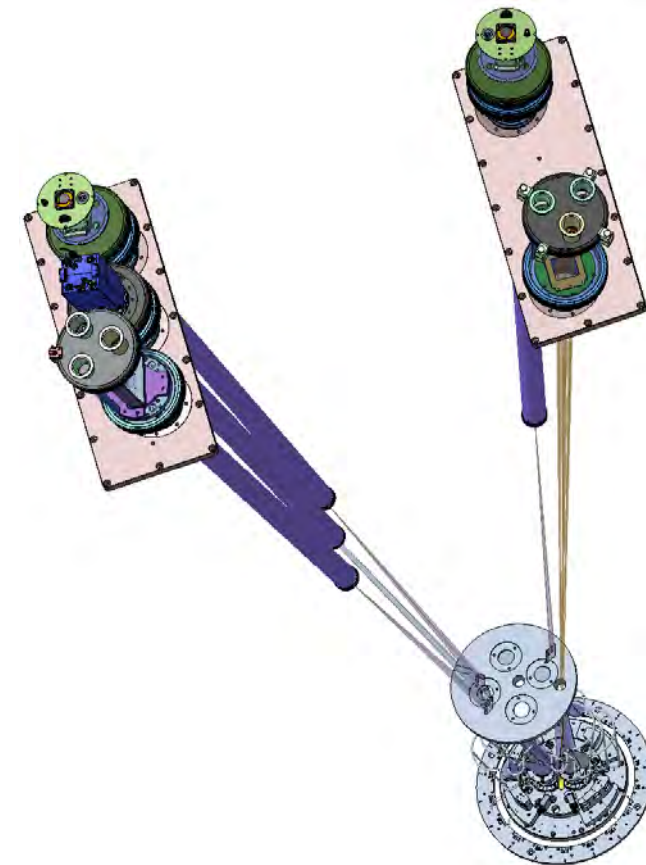

hCMOS based PHCs, Diode Arrays, UPAC (Linear diode array)

For more information contact Aaron Edens

X-Ray Imaging Capabilities



Diagnostic	Spectral band(s)	Spatial resolution	Temporal resolution	Field of view
HRCXI: High resolution continuum x-ray image (Eric Harding)	1 st order = 3.1069 keV ($\Delta = 2$ eV) 2 nd order = 6.2137 keV ($\Delta = 4$ eV) 3 rd order = 9.3206 keV ($\Delta = 6$ eV) 4 th order = 12.4275 keV ($\Delta = 8$ eV)	Mag ~ 5.8 15 μm x 15 μm	Time-integrated	3 mm wide and >10 mm tall
TRICXI: Time Resolved In-Chamber X-ray Imager (Tim Webb)	Minimum filter for debris mitigation 2 mm Kapton with additional filters possible Mag 3: 1 channel Mag 1: 3 channels	Mag 3: 31 μm (20 μm pinhole) Mag 1: 64 μm (20 μm pinhole)	Gen 2 MCP 0.15, 0.25, or 0.8 ns gates 8 frames	Mag 3: ~ 1 mm wide and ~ 12 mm tall Mag 1: ~ 3 mm wide and ~ 12 mm tall
TIPC: Time Integrated Pinhole Camera (Tim Webb)	Minimum filter for debris mitigation 1.5 mm Kapton 5 channels with additional filters	Mag 0.375: 190 μm (50 μm pinhole)	Time-integrated	Several cm in both directions
MLM: Multilayer mirror pinhole cameras (Ming Wu)	277 eV or 528 eV Can split frames between the two spectral bands	Mag 0.5: 320 μm (100 μm pinhole)	Two Gen 1 MCP 0.25 or 0.8 ns gates 6+8 = 14 frames	Several cm in both directions Views target at 13 degrees above horizontal
MLMC: Filtered pinhole camera (Ming Wu)	Filter options available from 1 μm aluminized-Lexan (> 0.5 keV) to 30 mils Kapton (> 5 keV)	Mag 0.5: 180 μm (50 μm pinhole)	Gen 1 MCP 0.25 or 0.8 ns gates 8 frames	Several cm in both directions Views target at 13 degrees above horizontal
Z beamlet x-ray backlighting (Aaron Edens)	6.151 keV, 7.242 keV, or 1.865 keV Can field two different configs	Mag ~ 6 : ~ 15 μm (limited by image plate)	1 ns long x-ray bursts recorded on image plate (2 separate LOS)	~ 10 mm wide and ~ 4 mm tall Frames are at ± 3 degrees from horizontal
FOA PHC: Final Optics Assembly pinhole camera (Aaron Edens)	Soft x-ray, minimum filter 2 μm poly carbonate 3-4 channels with additional filters per head Multiple heads available	Mag 1: ~ 600 μm (300 μm pinhole)	Multi-frame ultrafast x-ray imager: 2-8 frames, 2 ns gate Image plate: time-integrated	~ 1 cm Views target at ~ 7.5 degrees from vertical
MIP: Mirrored Imager Plasma emission acquisition systems (Greg Dunham)	Multilayer mirrors at 277 eV or 528 eV Can split frames between the two spectral bands	Mag 1: ~ 400 μm (200 μm pinhole)	2 Gen 1 MCP 0.15, 0.25, or 0.8 ns gates 8+8 = 16 frames	~ 8 mm Views target at ~ 9 degrees from vertical
Wolter (Jeff Fein)	Multilayer optics with ~ 1 keV bandpass centered at ~ 17.5 , 22.1, 22.6, and 23.5 keV	Mag 3.5: 30 x 100 μm	Time-integrated	~ 8 mm

For more information contact Eric Harding

X-Ray Spectroscopy Capabilities



Name	LOS ³	Crystal Geometry	Spatial Mag.	Energy range ^{1,2}	Spectral Resolution (E/dE)	Detector	Notes
CCP Greg Dunham	Top	Convex w/slit	1x	0.6-20 keV, $\Delta E \sim 4-10$ keV	>800	IP/Film or hCMOS (CCP-t)	Limited energy range for CCP-t
ECP Greg Dunham	Top	Elliptical w/slit	1x	0.6-13 keV, $\Delta E \sim 1 - 4$ keV	>800	IP or Film	Not routinely used
TREX Greg Dunham	Side (12°)	Elliptical w/slit	0.3x	0.6-13 keV, $\Delta E \sim 1 - 4$ keV	>800	MCP: 6 frames per crystal (12 total)	2-xstals: Both radially or axially resolving
TIXTL Greg Dunham	Side (12°)	Convex w/slit	0.3x	0.6-20 keV, $\Delta E \sim 4-10$ keV	>800	IP or Film	2-xstals: Both radially or axially resolving
CRITR Greg Dunham	Side (0°)	Cauchois w/slit	0.5x or 1.0x	8-50 keV, $\Delta E \sim 10$ keV	200-1200	IP or Film	Radially resolving (RR) or axially (AR).
TiGHER Kathy Chandler	Side (0°)	Cauchois w/slit	0.5x	8-20 keV (fixed)	200-1200	MCP (8 frames)	Axial resolution only
XRS3 Eric Harding	Side (~0°)	Spherical, focusing	0.3x	1-15 keV, $\Delta E \sim 1-3$ keV	4000	IP or Film	Radial or axial resolution.
MONSSTR Eric Harding	Side (0°)	Spherical, focusing	0.3x	1-15 keV, $\Delta E \sim 1-3$ keV	4000	hCMOS or IP	

1. The energy range is configuration and crystal dependent. Several options exist.

2. Crystal reflectivity may limit instrument sensitivity for reflection geometries at higher energies ($E > 10$ keV).

3. Angle measured up, vertically from the horizontal plane

For more information contact Eric Harding

X-Ray Power and Energy Capabilities



Diagnostic	Purpose	Energy Range (> 50% absorption)	LOS (max # fielded)	Total Available	Advantages	Notes
XRDs	Power	< 2 keV	50-12° (5), 210-12° (4), 170-0° (5*), Axial (2-7*)	Few dozen	Best response of “cold” spectra, fast	Needs calibration at synchrotron
Bolometers	Energy	< 7 keV	50-12° (3), 170-0° (1), 210-12° (1)	10-20	Considered intrinsically calibrated	No current source for new elements.
SIDs (COTS)	Power	< 7 keV	Any	Limited stock (no longer available)	Fairly repeatable	Not fully characterized
SIDs (SNL)*	Power	< 7 keV	Any	??	Well-defined volume	
TEP	Unfiltered source pulse shape	< 7 keV	50-12° (2)		No filtering required	Pulse shape only
PCDs	Power	< 8 keV	Any external	few dozen	Good pulse shape. Good for higher fluences.	Difficult to calibrate
GaAs diodes	Power	< 17 keV	Any	Assembled in small quantities	Better spectral range than SIDs and fast	Very reproducible
Calorimeter	Energy	< 150 keV	In-Chamber	2-3 can be fielded at once.	Best reference standard	Susceptible to debris in some circumstances
WALLE	Spectral Power	Varies	In-Chamber	1 (12-16 diodes)	Designed for time- resolved spectral unfolding.	Not well qualified

*Expanding capabilities early next FY

Visible and UV Spectroscopy Capabilities



System	Type	Wavelength range (nm)	Spectrometer length (m)	Dispersion range (nm/mm) ¹	Minimum Resolution (nm) ²	Sweeps speed (ns) / Minimum gate time (ns)	Notes
SVS 1	Streaked Visible	400-700	1	0.42 - 19.9	0.009	30-480	Recently upgraded to CCD
SVS 2	Streaked Visible	400-600	1	0.42 - 19.9	0.009	25-400	Recently upgraded to CCD
SVS 3	Gated Visible	400-700	0.32	1.2 - 59.6	0.04	7	
SVS 4	Streaked Visible	400-700	1	0.42 - 19.9	0.009	100-2000	
SVS 5	Streaked Visible	400-700	1	0.42 - 19.9	0.009	100-2000	
SVS 6	Gated Visible	400-700	0.67	0.62 - 29.8	0.02	2	Also has a 500 ps gate mode
SVS 7	8 Framed Gated Visible	400-700	0.67	0.62 - 29.8	0.02	2.5	8 frames can be spaced up to 10 ms apart (250 ps steps)
SVS 8	Gated UV	200-700	0.32	1.2 - 59.6	0.04	7	

Note: While this is the current pairing for the spectrometers/cameras they can be rearranged if needed

¹Dispersion range is found for using a 2400 and a 50 l/mm grating.

²Ideal minimum resolution for a 2400 l/mm grating, this can increase based on slit size and detector.

All detectors are now CCDs!

For more information contact Mark Johnston or Jacob Banasek

Diagnostic Development Activities



- Equatorial Line of Sight*
- Nuclear Burn History
- NIF to Z tech transfer effort
 - X-Ray Streak Camera*
 - Precision nToF
 - 2D neutron imaging
- Compact Recoil Spectrometer*
- Next Generation hCMOS (shorter integration times, tiling, higher energy)
- X-Ray Diffraction*
- Multi-frame Backlighting (4 frames)
- Laser Imaging*
- Ultrafast Pixel Array Camera (UPAC)*
- Film and Image Plate Scanning Systems*
- And many more

Implementing a Horizontal Line of Sight Capability on Z

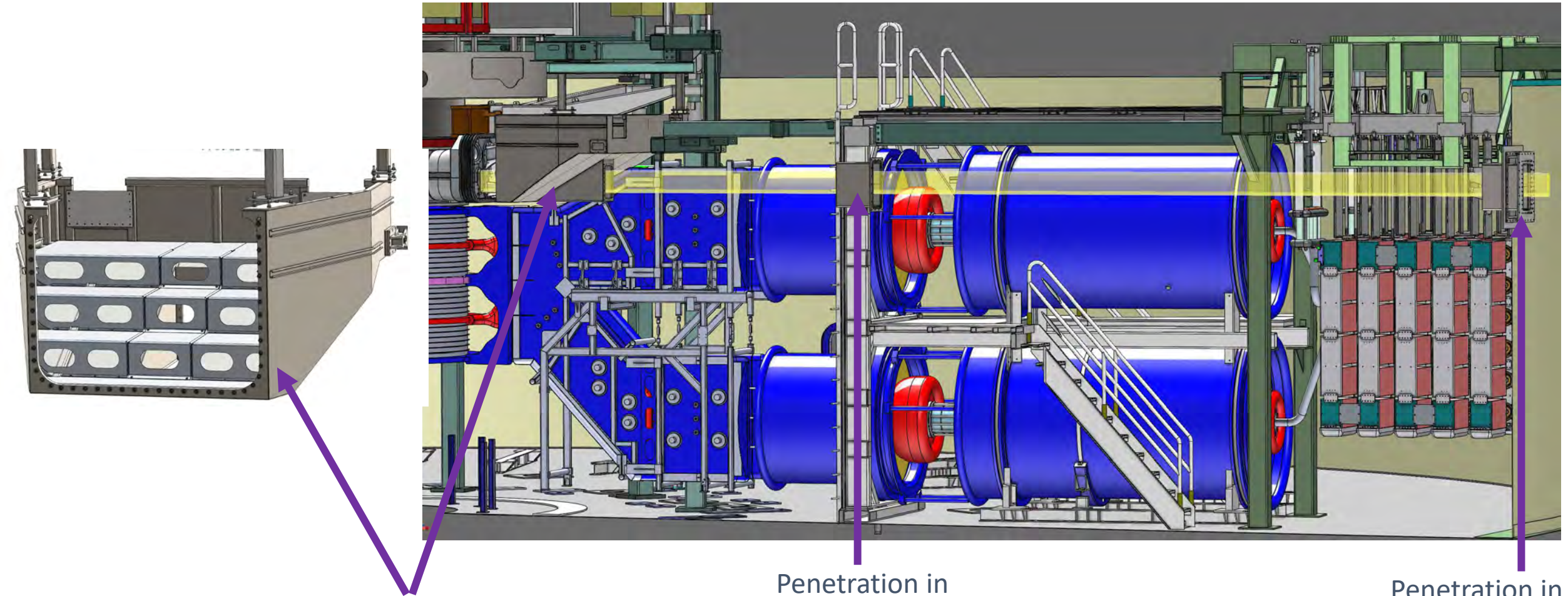

A new diagnostic boat (8' wide x 12' long) has been designed and a procurement has begun for 4 units.

Penetration in
Water/Oil Wall

Penetration in
Oil/Air Wall

For more information contact Decker Spencer

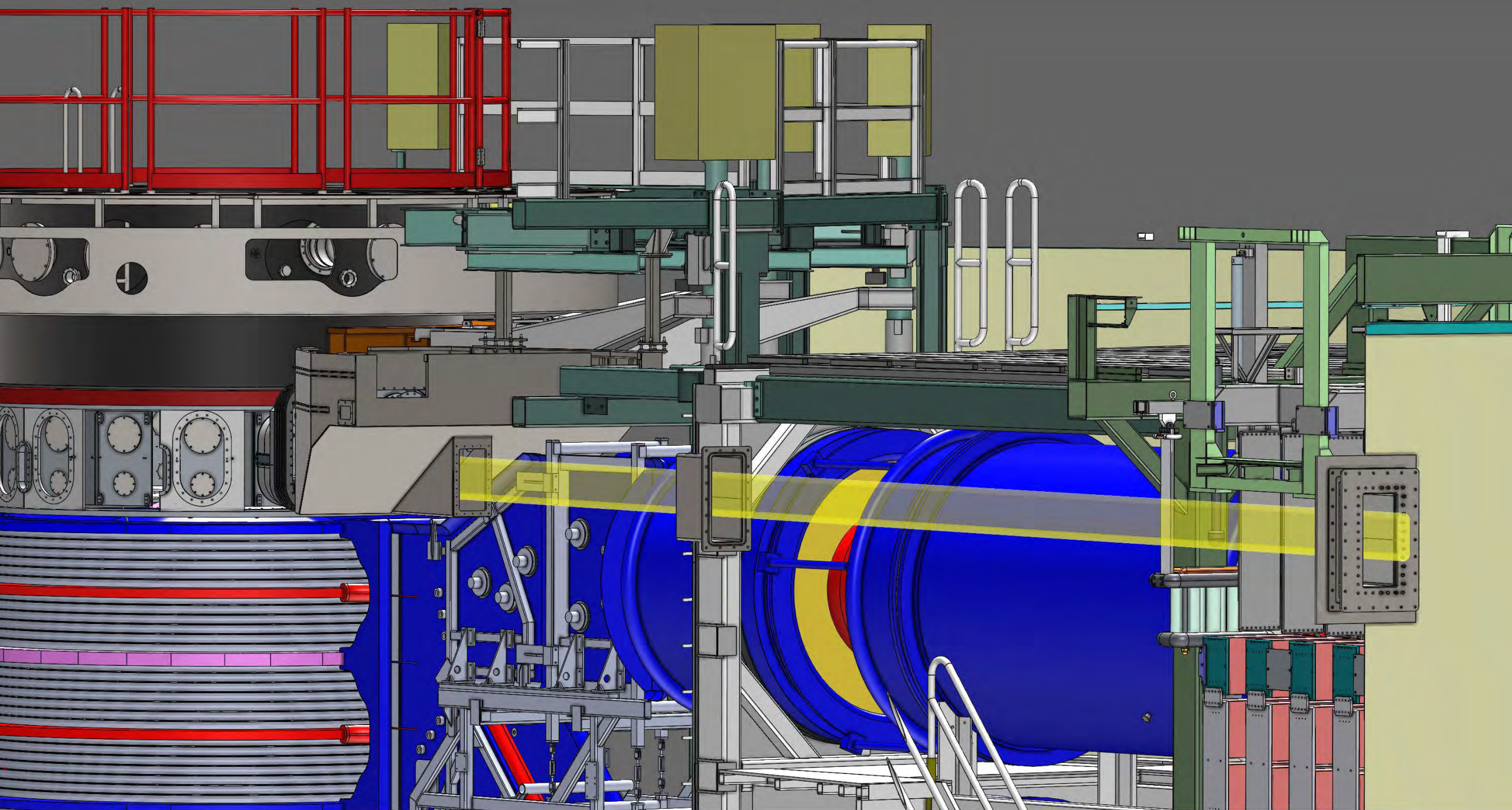

For more information contact Decker Spencer

Status Update: Streak Camera Development for Z



- The SCORPIONZ (Streak Camera Observatory with Radial and Polar Implementation ON Z) shall record the time-resolved X-ray emission from Z experiments. Similar to SPIDER on NIF.

- Key Expectations for SCORPIONZ:

- Record X-ray emissions in the energy range of 1-15keV in a radial location and a polar location on the Z machine, and additionally be able to record emissions at 0.2-2keV in the polar location
 - Have a spatial record and temporal record of 200 elements each
 - At temporal windows of 2, 5, 10, 20, 50 & 100ns
 - At a temporal resolution of at least 25ps
- Estimated to be installed on Z summer of 2023

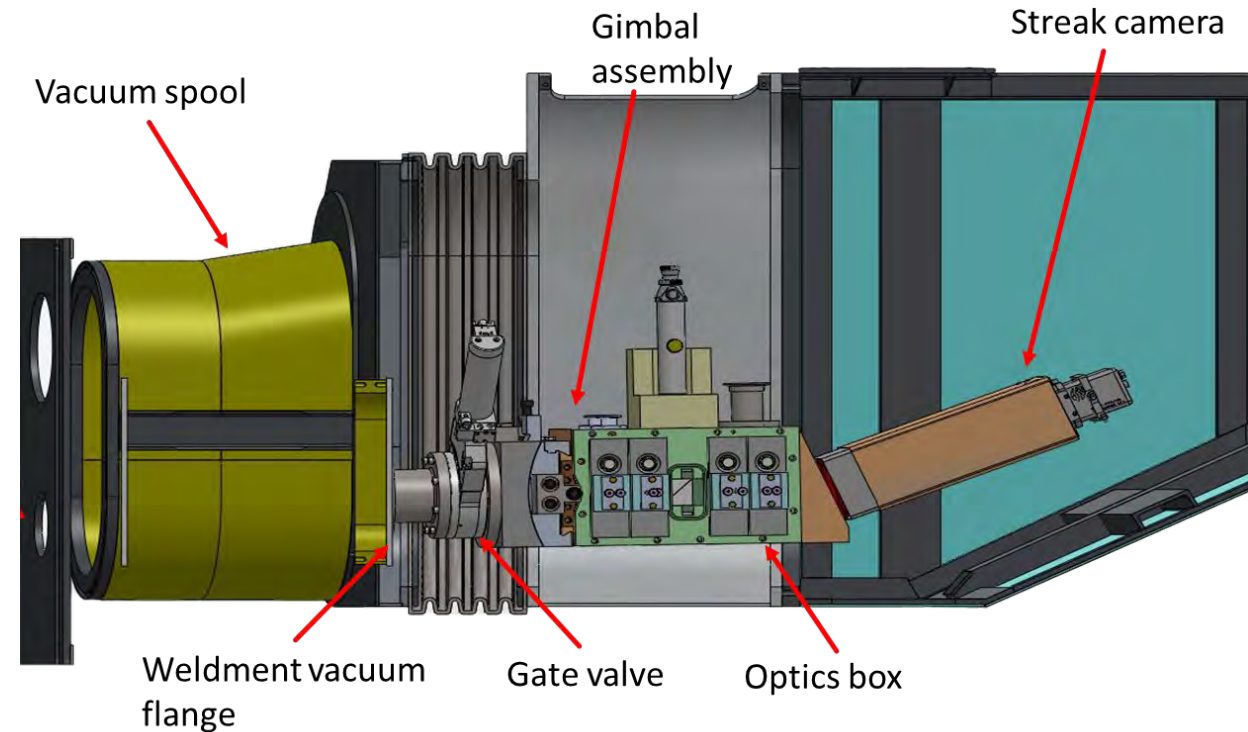

Phase 1a – Radial at LOS90 (Summer 2023)

Phase 1b – Axial Package

Phase 2 – Streaked 1-D imaging

Phase 3 – Streaked Spectroscopy

A compact recoil spectrometer has been developed to measure the primary fusion yield and liner areal density in MagLIF implosions



Compact Recoil Spectrometer (CRS)

Data from Ion Beam Lab (IBL) experiments

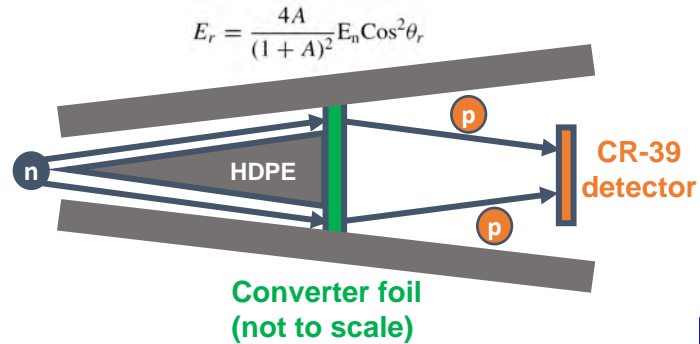

Recoiled protons leave tracks in the CR39 which can be seen after etching

Etched CR39

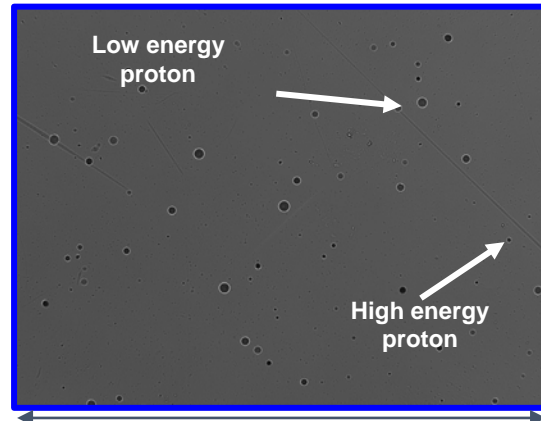

The track diameter distribution is used to infer the recoil proton energy spectrum

CRS at the Ion Beam Lab (IBL)

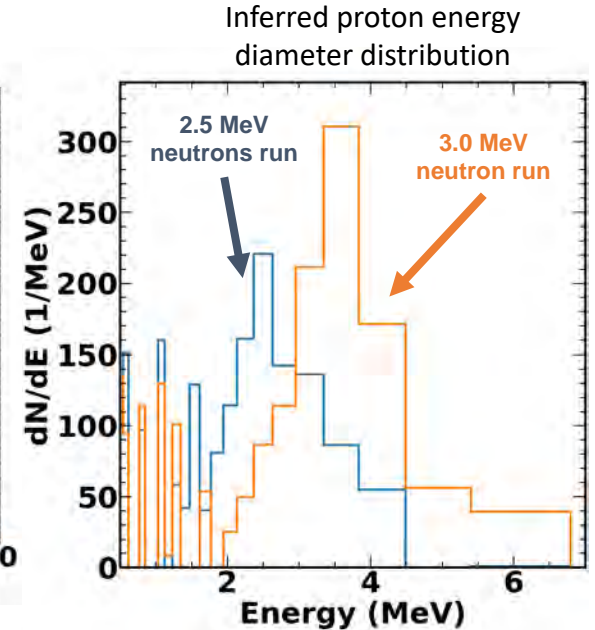
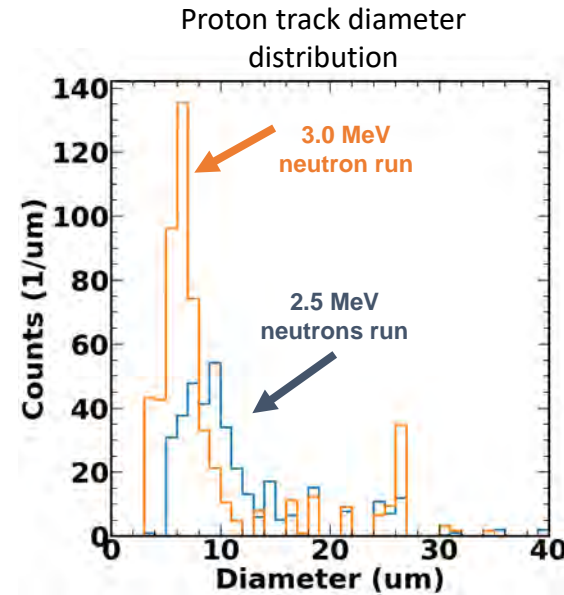
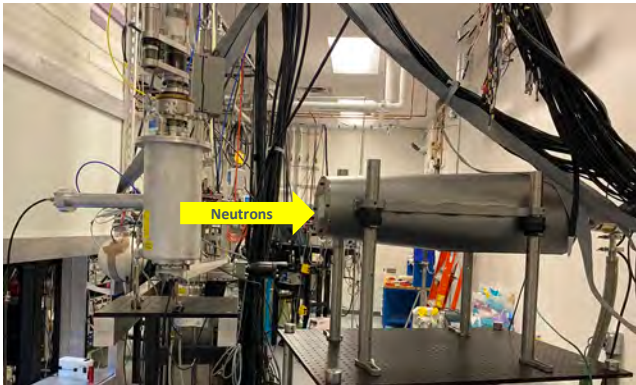

CRS will be commissioned on Z in August 2022.

SEGOI modifies existing Z Line VISAR infrastructure to enable side-on visible self-emission images



Self-emission gated optical imager (SEGOI)

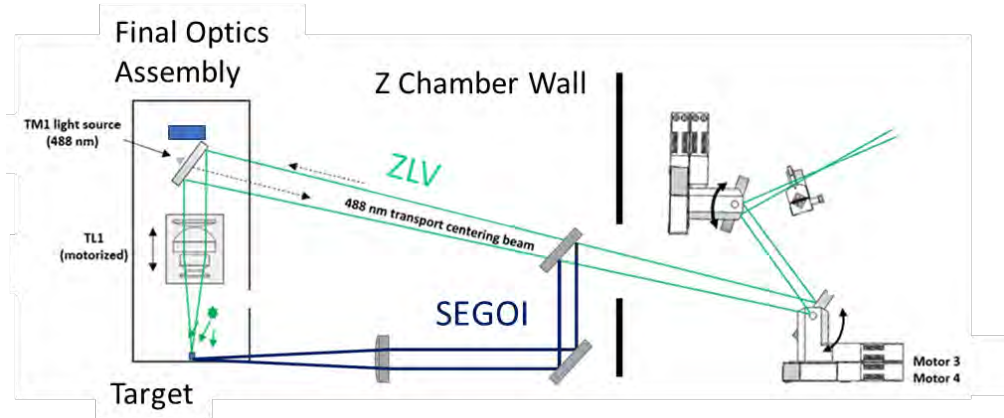

SEGOI modifies the existing Z Line VISAR (ZLV) image relay and camera systems to generate side-on images of Z targets and transmission lines

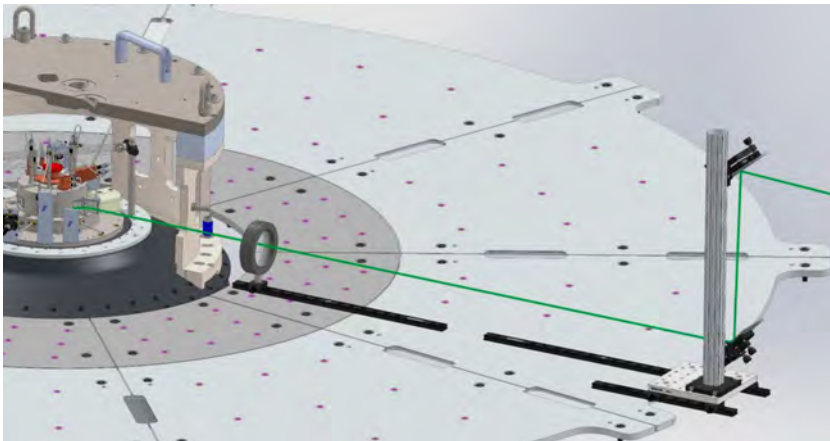

ZLV transports 540-650 nm light to:

- 8 GOIs (≥ 100 ps gate)
- 2 streak cameras (62 and 94 ns duration)

Recent data from ICF and ZFS experiments

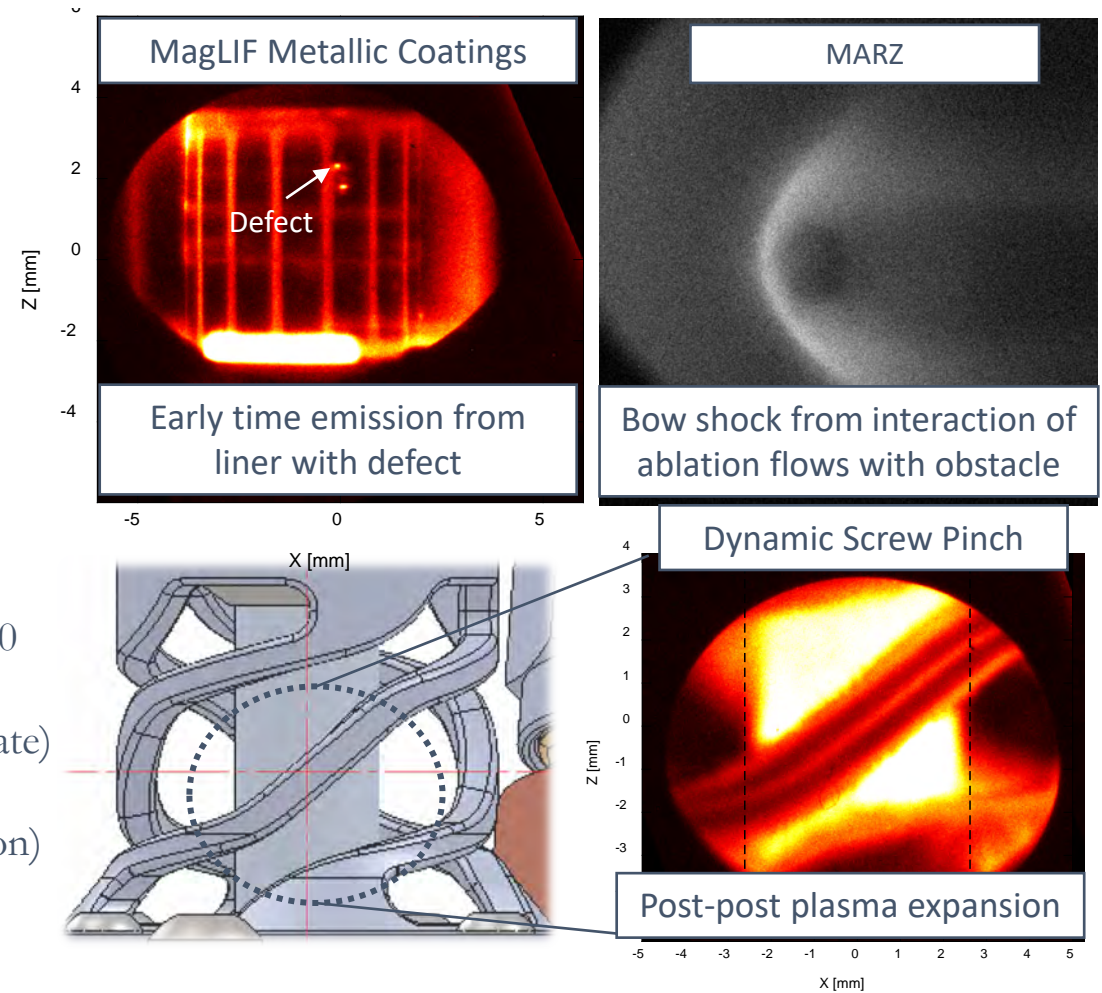

Future work includes coupling **laser imaging** to SEGOI for shadowgraphy, interferometry, and Faraday rotation imaging (ongoing LDRD)

For more information contact David Yager-Elorriaga

PDV measures real and apparent motion with optical fiber



Capabilities

- 24 frequency-shifted channels around 1550 nm
 - No minimum velocity
 - Up to 19 km/s directly, 20+ km/s with leapfrog
 - Directionally sensitive
 - Bidirectional, unidirectional, passive, and null probe configurations
- *Limited support for 1064/1310 nm measurements*
- Detects **optical path** changes
 - Moving reflectors
 - Refractive index changes
- Applications at Z
 - Flyer, interface, and shock velocity
 - Current delivery (requires unfold)
 - Plasma density estimation
 - Radiation detection

Material studies

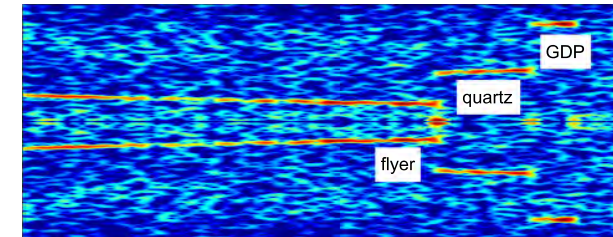

Plasma density

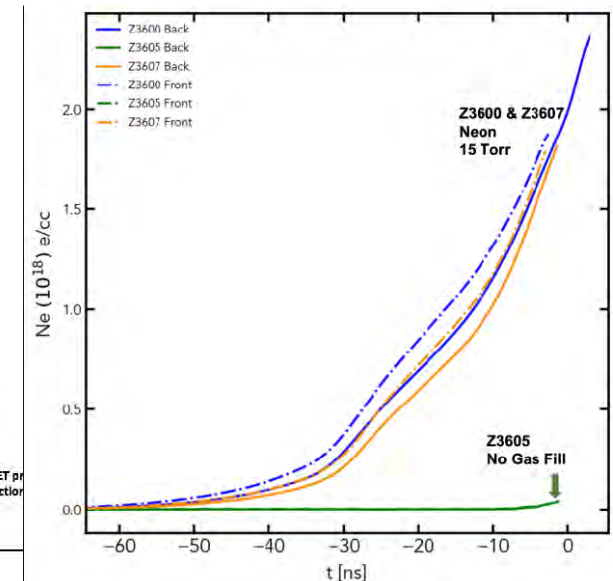
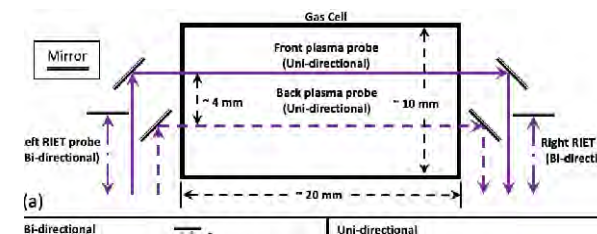
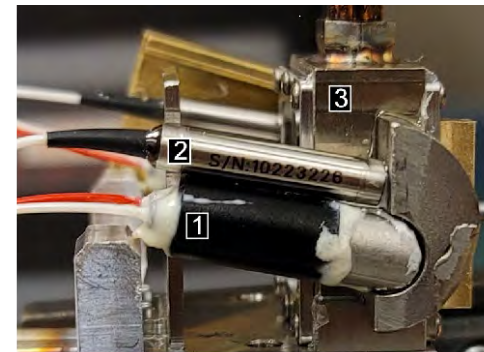

Z data film scanning team is testing modern scanning platform with promising results



DT Atom scanner provides instant image capture

- Phase One sensor (150MP)
- Stable LED light source
- Stable film holder with AR glass
- Adjustable to a wide range of focal lengths, film sizes, and resolution (limit beyond the size of a single grain in film.)
- Modular design allows repair, replacement, and upgrade.
- Utilizes modern Capture One photography software to control all aspects of image creation including meta data storage.



Testing shows reasonable agreement between both instant capture and Microdensitometry.

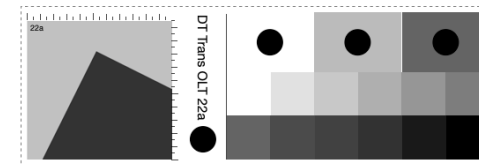
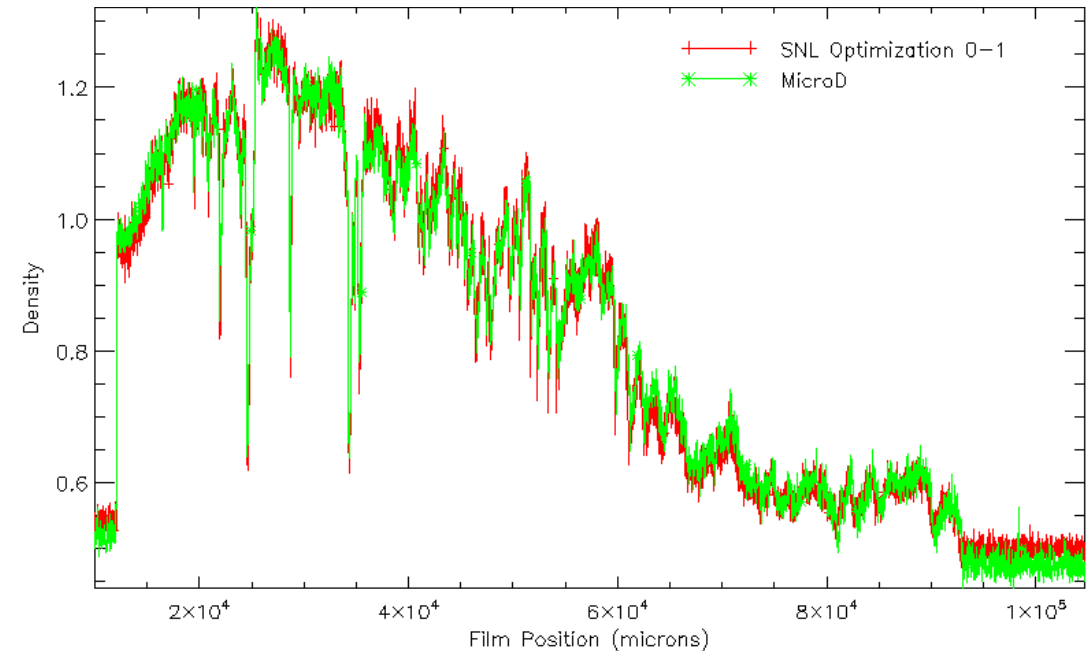

Test pattern embedded in each exposure provides record of tonal response, resolution, and sharpness.

Filter, XRD, Crystal and Multilayer Mirror Calibrations Using Synchrotron Beamline 16-2 at SSRL in the Energy Range of 50 – 2200 eV.



SSRL Beamline 16-2 and End Station

Recent Results

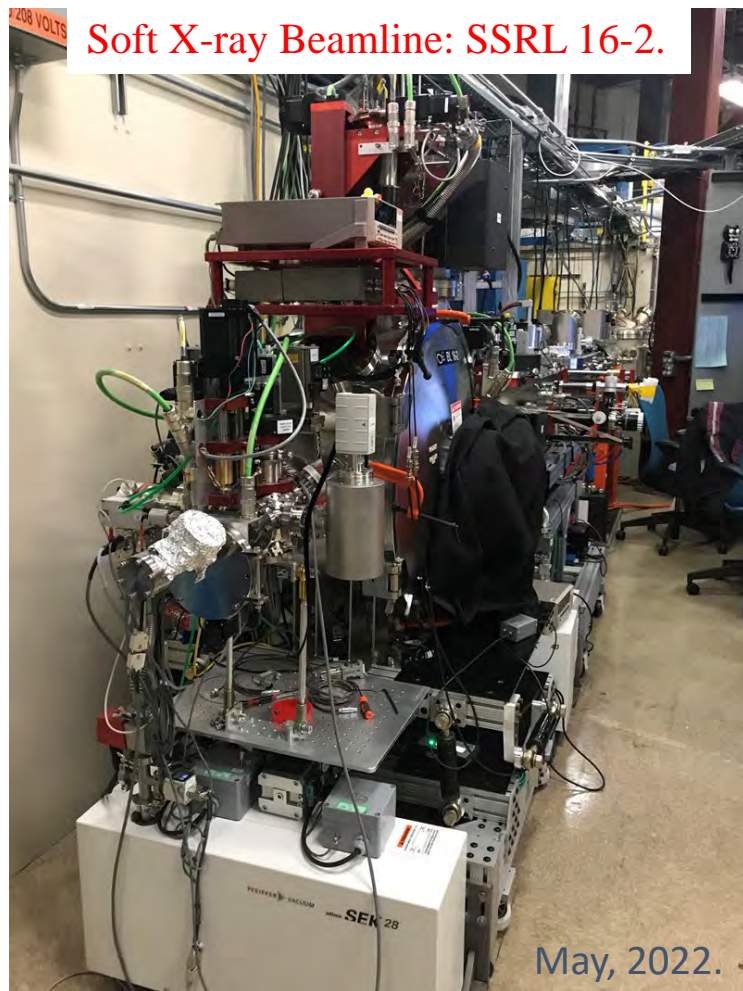

Soft X-ray Beamline: SSRL 16-2.

May, 2022.

Beam size: 5 mm x 1 mm
 Detectors: AXUV100GX; Amptek Fast SDD
 Sample Stage: 5 axis (x-y-z- θ -tilt)

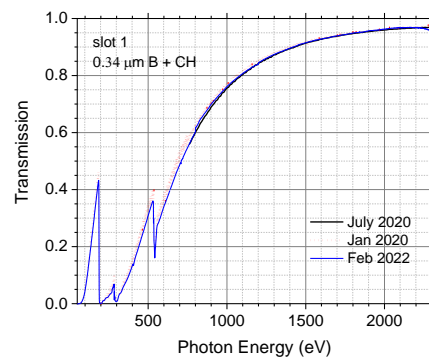

Filter Calibrations

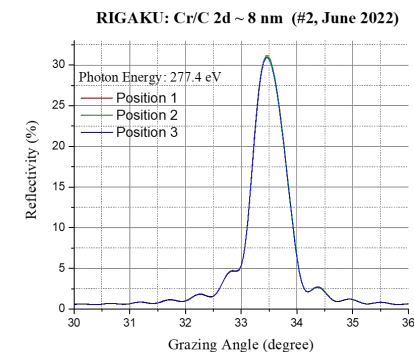
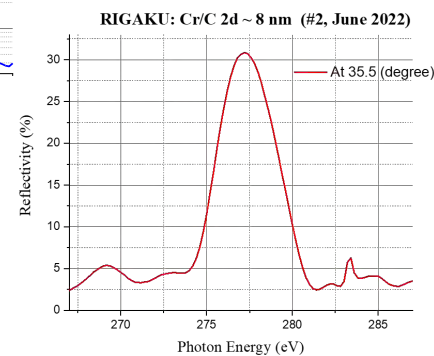
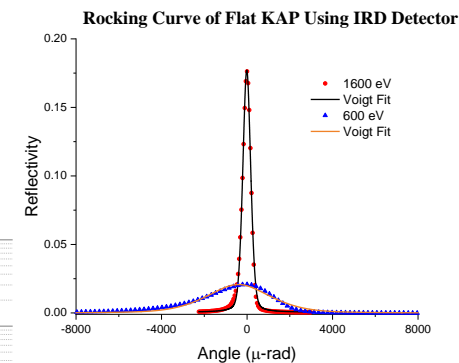
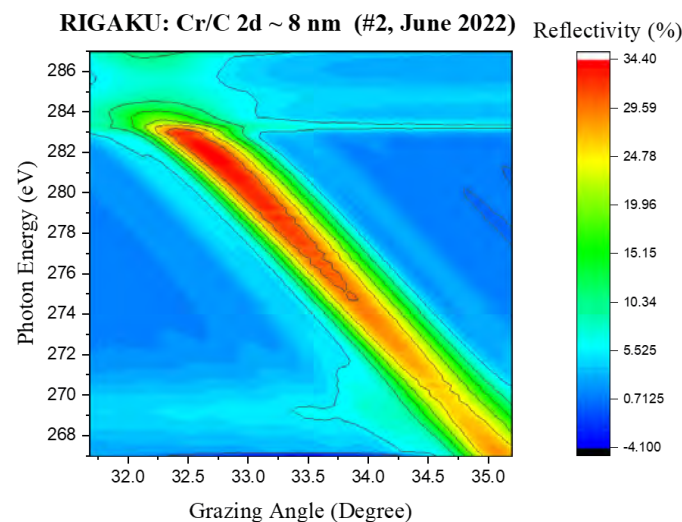
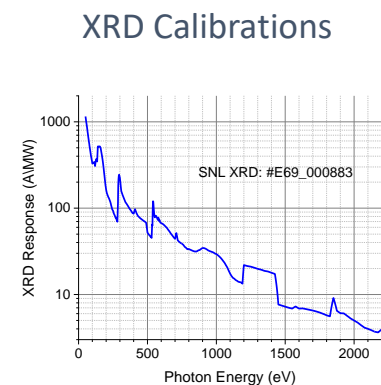

For more information contact Ming Wu

The Ultrafast Pixel Array Camera (UPAC) is a flexible platform with 32 digitizing channels at 9.25 Gbps



- Designed to operate like UXI camera – same volume, mounting scheme, power requirements, control/readout cabling, etc.
- Complementary data set – sparse spatial information for better temporal coverage

System View

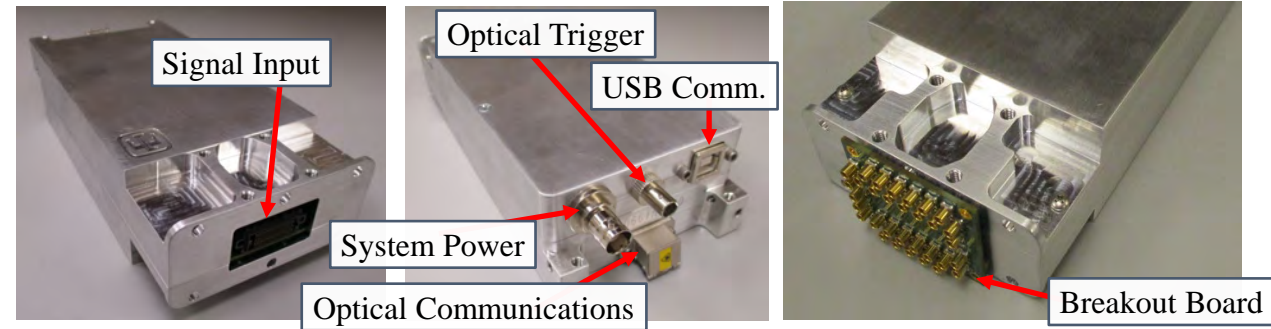

Key Specifications

Number of Channels	32
Sample Rate	9.25 Gbps
Analog Bandwidth	1.8 GHz
Record Length	114 ns
Coupling	AC
Input Range	0.1 – 0.9 V
Power Requirement	7.5 – 9 V DC, 700 mA

Enabling Technology: PSEC4A Chip

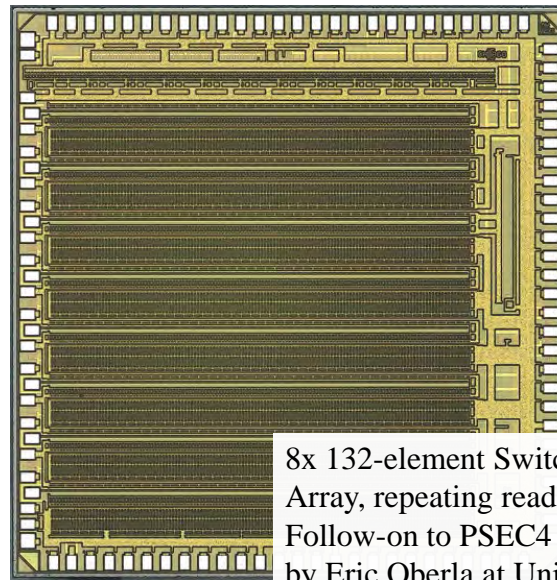

8x 132-element Switched Capacitor Array, repeating readout buffer. Follow-on to PSEC4 [1], designed by Eric Oberla at Univ. of Chicago.

Host Board

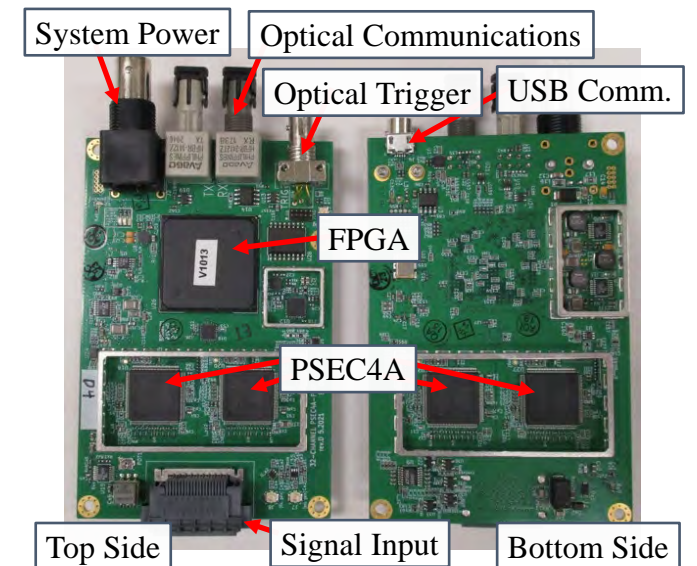

[1] E. Oberla et al., NIMA vol. 735, p. 452 (2014)

The UPAC can enable new measurement techniques



Solid State Streak Camera

- 32-element linear diode array detector card
- Array size 8 mm x 0.75 mm, 0.25 mm pitch
- Several times efficiency of most photocathodes for X-Rays in the $\sim 0.5 - 10$ keV range
- Example data: 670 nm laser illumination over broad area, 440 nm laser illumination at different place and time

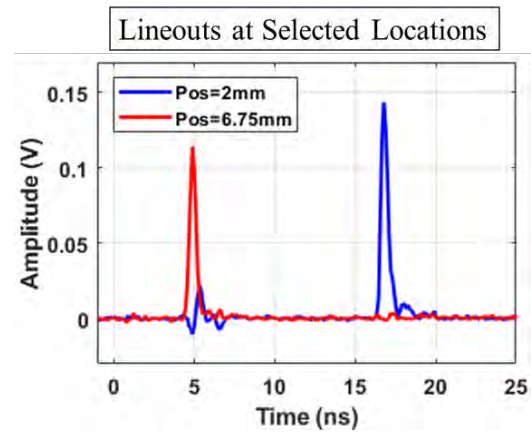
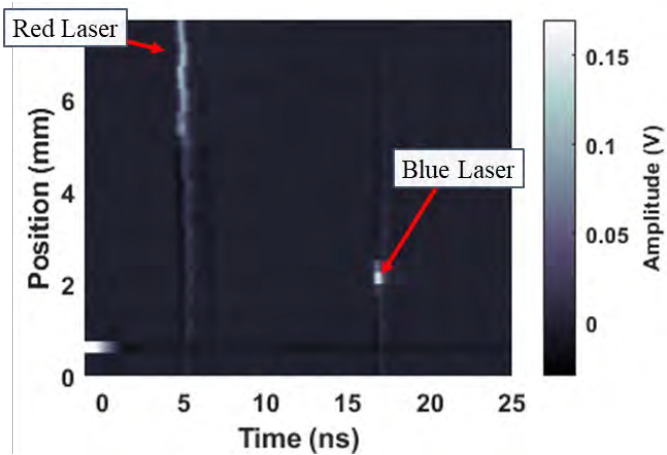

nToF Single-Neutron Counter

- Splitting detector volume into many elements reduces pile-up, making possible detection of single interactions rather than aggregate data
- Only rise time is needed for particle arrival, effectively removing instrument impulse response

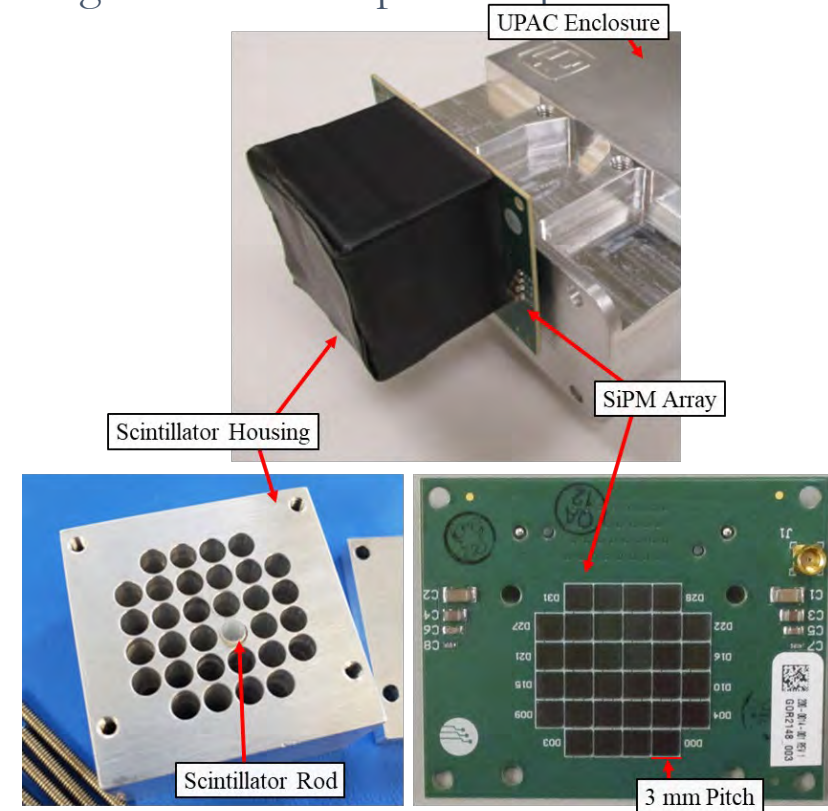

For more information contact Quinn Looker

X-Ray Diffraction successfully implemented on Z using DISCO

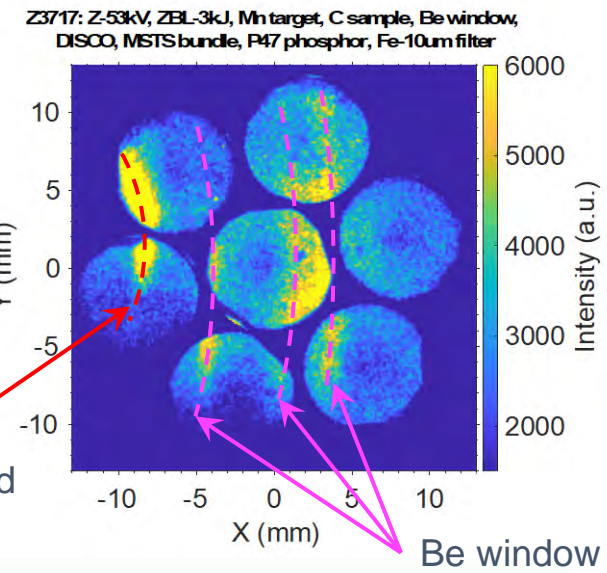
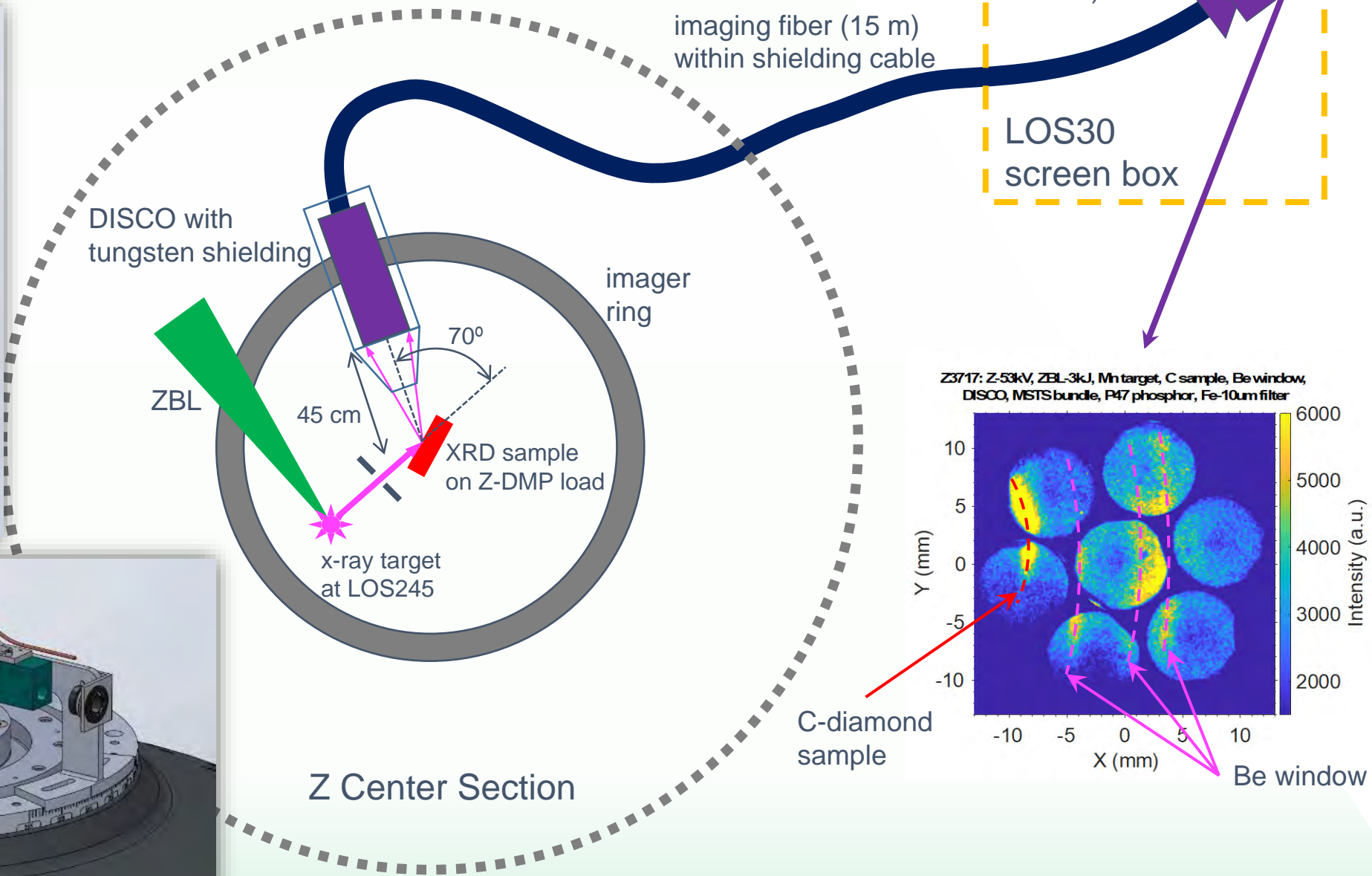
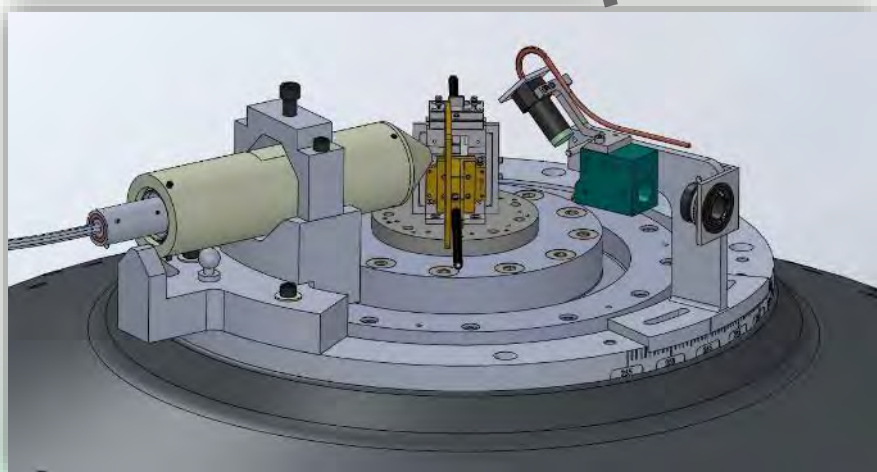
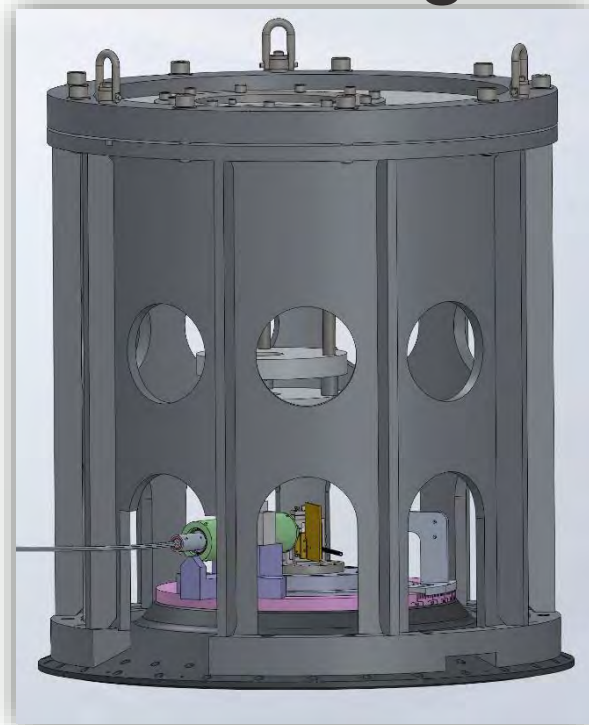

For more information contact Tommy Ao

Diffraction SCintillator Optic (DISCO)



Scheme

- Time-gated detector close to load to cover large solid angle
- X-ray conversion to optical light via scintillator or phosphor
- Signal transport with imaging fiber bundle to a gated camera

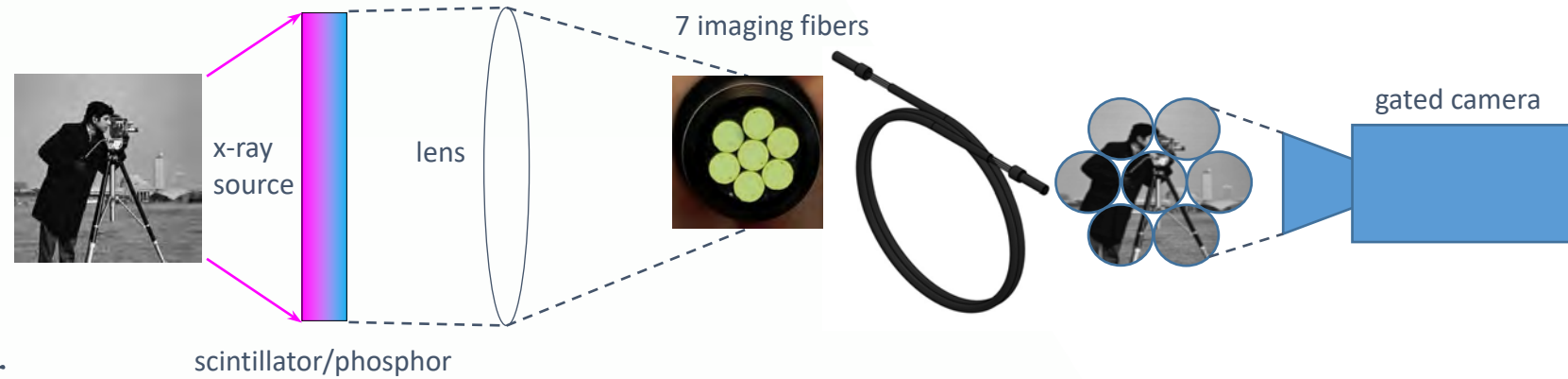

Key specs

- 23 mm active diameter, $\sim 15 \mu\text{m}$ spatial resolution
- Phosphor decay: 100 ns, 1 us, 1 ms
- At 25 mm distance: 50° angular coverage, 0.2° resolution

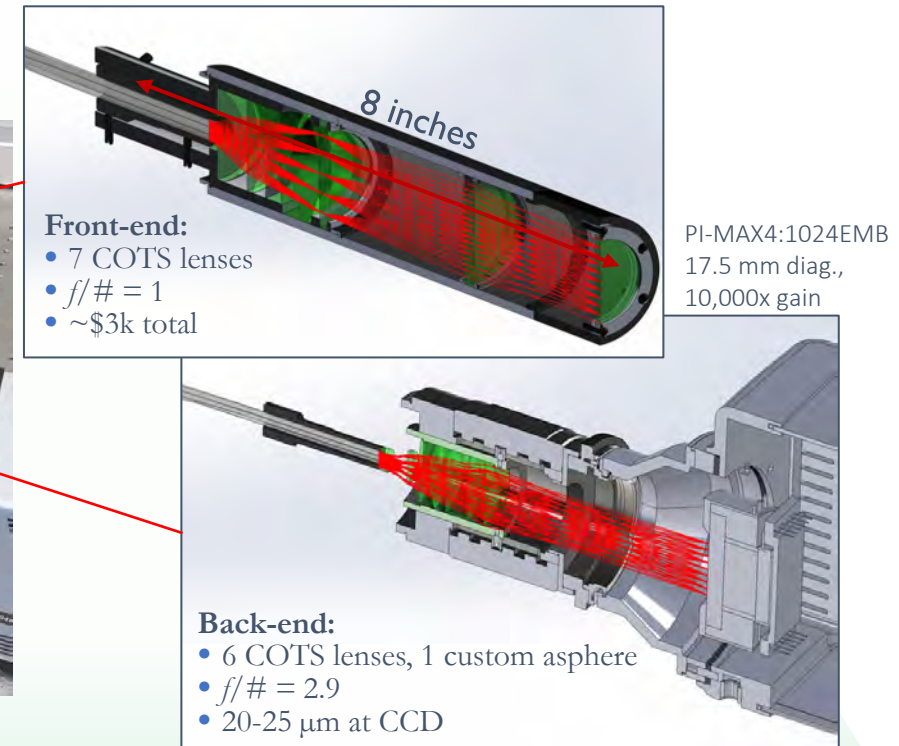
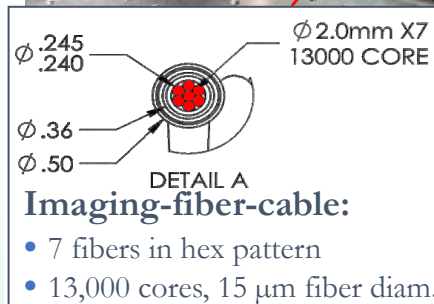
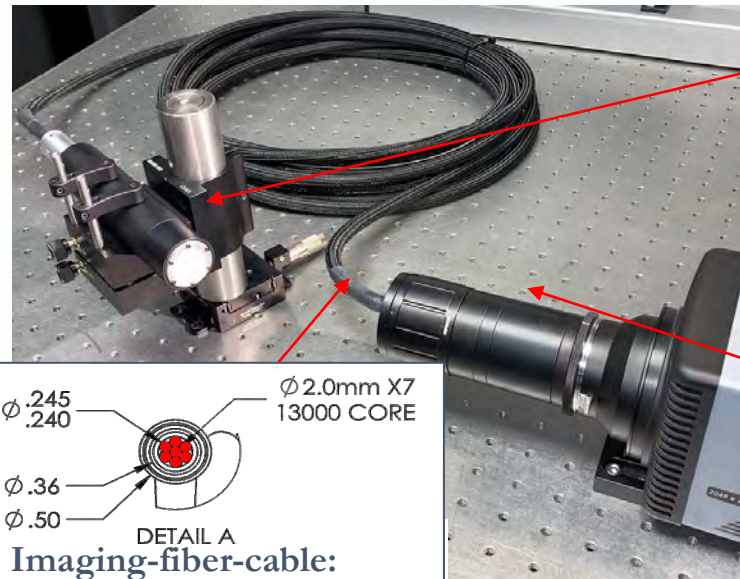

Commissioned a Deuterium Ice Extruder on Z



- Deuterium ice extruder enabled evaluation of a new ICF fuel configuration
- Extruder development is described in [Rev. Sci. Instrum. 92, 073505 \(2021\)](#)
- Screw drives ice through 300-um-diameter nozzle—extrudes fiber which passes through the target
 - Presence of fiber confirmed via video capability positioned below target (cathode)
- Two Cryogenic Development shots (Z3690 and Z3690) executed on April 6 and 8, 2022

Extruder Operation:

- Fill cryostat with ice via desublimation
- Drive screw downward:
 - Close gas line
 - Pack ice
 - Initiate extrusion
- Continuous extrusion through Z charge and fire sequence

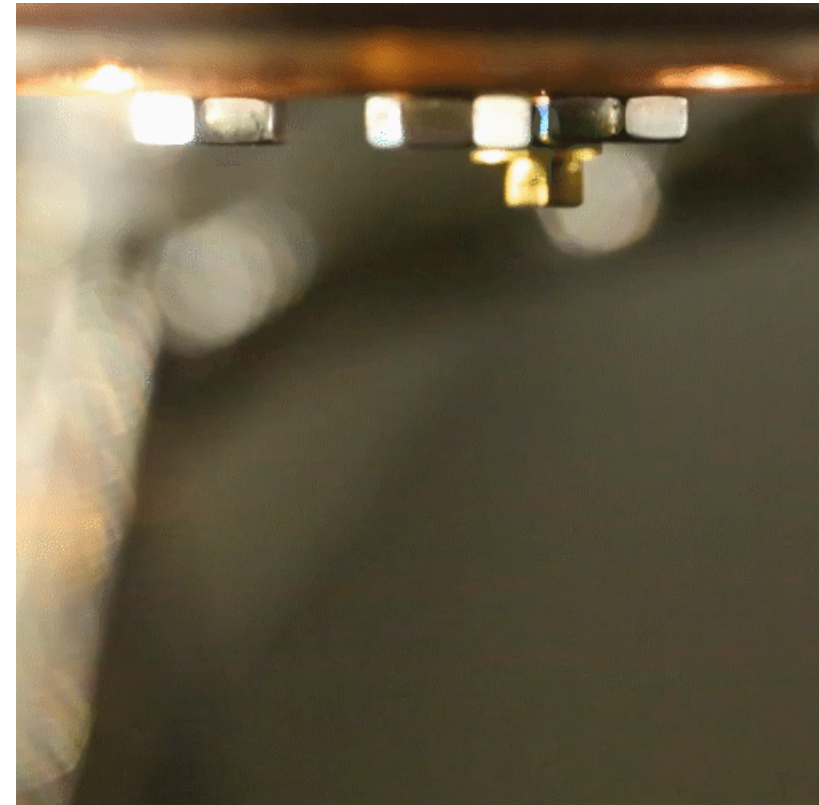
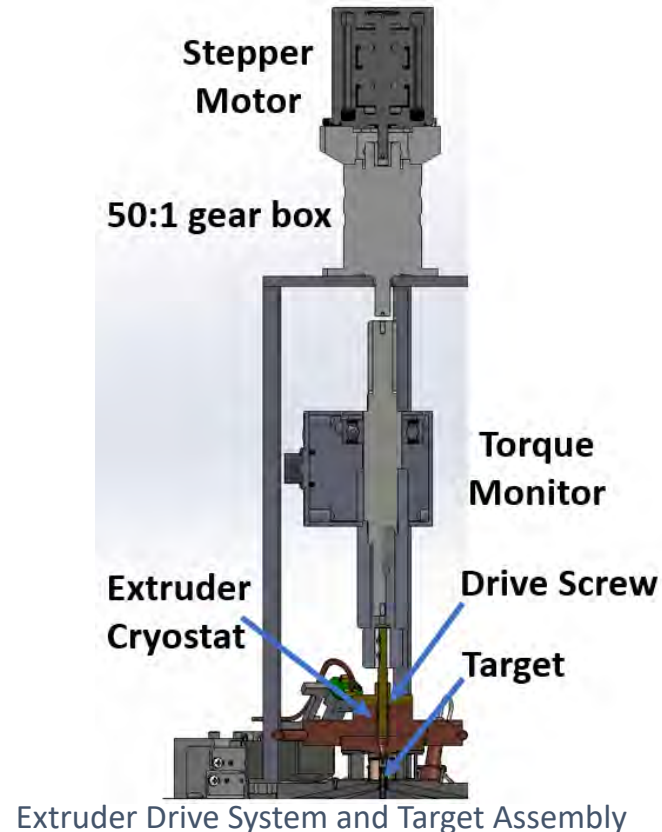

For those who have access to internal SNL resources a plethora of diagnostic information can be found



Summary table that lists each diagnostic along with the diagnostic scientist, data location, and publications.

<https://wiki.sandia.gov/display/ZD/Diagnostic+Instruments>

Title	1 Area	2 Scientist	7 Data Location	9 Publications
X-Ray Diodes (XRDs)	Power and Energy	Tim Webb	\\fszmain\z_archive	X-ray power and yield measurements at the refurbished Z machine - https://doi.org/10.1063/1.4891316 Filtered x-ray diode diagnostics fielded on the Z accelerator for source power measurements - https://doi.org/10.1063/1.1149355 D.L. Fehl, et al, RSI, 68, 1997;
WALLE	Power and Energy	Tim Webb	\\fszmain\z_archive	WALLE - DAHX - The differential absorption hard x-ray spectrometer at the Z facility - https://doi.org/10.1109/TPS.2017.2723347
TRES	Spectroscopy	Ming Wu	Images: \\snl\Collaborative\minion \MicroD\Z_Shots Timing: \\fszmain\z_archive	Time- and space-resolved elliptical crystal spectrometers for high energy density physics research - https://doi.org/10.1063/1.1788866

Other information on the Diagnostic Wiki Page:

- Diagnostic Responsibility Matrix – lists team members for each diagnostic
- Diagnostic Lecture Series Presentations
- LOS Port Allocation
- Screenbox and Diagnostic Mezz Allocation
- Individual Diagnostic Pages

For those who have access to internal SNL resources a plethora of diagnostic information can be found



Summary table that lists each diagnostic along with the diagnostic scientist, data location, and publications.

<https://wiki.sandia.gov/display/ZD/Diagnostic+Instruments>

Title	1 Area	2 Scientist	7 Data Location	9 Publications
X-Ray Diodes (XRDs)	Power and Energy	Tim Webb	\\fszmain\z_archive	X-ray power and yield measurements at the refurbished Z machine - https://doi.org/10.1063/1.4891316 Filtered x-ray diode diagnostics fielded on the Z accelerator for source power measurements - https://doi.org/10.1063/1.1149355 D.L. Fehl, et al, RSI, 68, 1997;
WALLE	Power and Energy	Tim Webb	\\fszmain\z_archive	WALLE - DAHX - The differential absorption hard x-ray spectrometer at the Z facility - https://doi.org/10.1109/TPS.2017.2723347
TRES	Spectroscopy	Ming Wu	Images: \\snl\Collaborative\minion \MicroD\Z_Shots Timing: \\fszmain\z_archive	Time- and space-resolved elliptical crystal spectrometers for high energy density physics research - https://doi.org/10.1063/1.4788866

Other information on the Diagnostic Wiki Page:

- Diagnostic Responsibility Matrix – lists team members for each diagnostic
- Diagnostic Lecture Series Presentations
- LOS Port Allocation
- Screenbox and Diagnostic Mezz Allocation
- Individual Diagnostic Pages

Thanks for your time

I can be contacted at micjone@sandia.gov if you have any additional questions.